

# TX-28/21MK1/M Service Manual

Specifications

Parts List

Safety

Block  
Diagrams

Service  
Information

Schematic  
Diagrams

Exploded  
View

PCB  
Views

## Service Support

Service and repair of this product is supported by Panasonic's LUCI interface.

This interface provides a link between the TV and a standard PC to allow a number of diagnostic and control functions to be performed.

For more details contact your local Panasonic company.

  
BACK

EXIT

# Service Manual



## Colour Television

### TX-28MK1/M

### TX-21MK1/M

## EURO-4 Chassis

### SPECIFICATIONS

(Information in brackets {} refers to model TX-21MK1/M)

<b>Power Source:</b>	220-240V a.c., 50Hz
<b>Power Consumption:</b>	85W {71W}
<b>Stand-by Power Consumption:</b>	1,8W
<b>Aerial Impedance:</b>	75Ω unbalanced, Coaxial Type
<b>Receiving System:</b>	PAL I, PAL-525/60 M.NTSC NTSC (AV only)
<b>Receiving Channels:</b>	UHF E21-E69
<b>Intermediate Frequency:</b>	
<b>Video/Audio</b>	
Video	39,5MHz
Audio	33,5MHz
Colour	32,95MHz (NICAM) 35,07MHz
<b>Terminals:</b>	
AUDIO MONITOR OUT	Audio (RCAx2) 500mV rms 1kΩ
AV1 IN	Video (21 pin) 1V p-p 75Ω Audio (21 pin) 500mV rms 10kΩ RGB (21 pin)
AV1 OUT	Video (21 pin) 1V p-p 75Ω Audio (21 pin) 500mV rms 1kΩ

AV2 IN	Video (21 pin) Audio (21 pin) S-Video IN (21-pin)	1V p-p 75Ω 500mV rms 10kΩ Y: 1V p-p 75Ω C:0,3V p-p 75Ω
--------	--	---

AV2 OUT	Video (21 pin) Audio (21 pin) Selectable output (21 pin)	1V p-p 75Ω 500mV rms 1kΩ
AV3 IN	Audio (RCAx2) Video (RCAx1)	500mV rms 10kΩ 1V p-p 75Ω

<b>High Voltage:</b>	28,2kV ± 1kV	{28kV ± 1kV}
<b>Picture Tube:</b>	A66ECF50X42 {A51EER35X70	66cm 51cm}
<b>Audio Output:</b>	2 x 15W (Music Power) 8Ω Impedance	
<b>Headphones:</b>	8Ω Impedance 3,5mm	

<b>Accessories supplied :</b>	Remote Control 2 x R6 (UM3) Batteries T.V. Stand TS2800 / TS2800S
-------------------------------	---

<b>Dimensions:</b>		
Height:	580mm	{481mm}
Width:	666mm	{525mm}
Depth:	472mm	{477mm}

<b>Net weight:</b>	31kg	{22kg}
--------------------	------	--------

Specifications are subject to change without notice.  
Weights and dimensions shown are approximate.

**NOTE:** This Service Manual should be used in conjunction with the EURO-4 Technical guide.

# CONTENTS

SAFETY PRECAUTIONS.....	2
SERVICE HINTS.....	3
SERVICE POSITION.....	4
ADJUSTMENT PROCEDURE AND FACTORY SETTINGS.....	5
WAVEFORM PATTERN TABLE.....	6
ALIGNMENT SETTINGS.....	7
BLOCK DIAGRAMS.....	8
PARTS LOCATION.....	12
REPLACEMENT PARTS LIST.....	13
SCHEMATIC DIAGRAMS.....	23
CONDUCTOR VIEWS.....	28

## SAFETY PRECAUTIONS

### GENERAL GUIDE LINES

1. It is advisable to insert an isolation transformer in the a.c. supply before servicing a hot chassis.
2. When servicing, observe the original lead dress in the high voltage circuits. If a short circuit is found, replace all parts that have been overheated or damaged by the short circuit.
3. After servicing, see that all the protective devices such as insulation barriers, insulation papers, shields and isolation R-C combinations are correctly installed.
4. When the receiver is not being used for a long period of time, unplug the power cord from the a.c. outlet.
5. Potentials as high as 29,2kV {29kV} are present when this receiver is in operation. Operation of the receiver without the rear cover involves the danger of a shock hazard from the receiver power supply. Servicing should not be attempted by anyone who is not familiar with the precautions necessary when working on high voltage equipment. Always discharge the anode of the tube.
6. After servicing make the following leakage current checks to prevent the customer from being exposed to shock hazard.

### LEAKAGE CURRENT COLD CHECK

1. Unplug the a.c. cord and connect a jumper between the two prongs of the plug.
2. Turn on the receiver's power switch.
3. Measure the resistance value with an ohmmeter, between the jumpered a.c. plug and each exposed metallic cabinet part on the receiver, such as screw heads, aerials, connectors, control shafts etc. When the exposed metallic part has a return path to the chassis, the reading should be between 4M ohm and 20M ohm. When the exposed metal does not have a return path to the chassis, the reading must be infinite.

### LEAKAGE CURRENT HOT CHECK

1. Plug the a.c. cord directly into the a.c. outlet. Do not use an isolation transformer for this check.
2. Connect a 2kΩ 10W resistor in series with an exposed metallic part on the receiver and an earth, such as a water pipe.
3. Use an a.c. voltmeter with high impedance to measure the potential across the resistor.
4. Check each exposed metallic part and check the voltage at each point.

5. Reverse the a.c. plug at the outlet and repeat each of the above measurements.
6. The potential at any point should not exceed 1,4Vrms. In case a measurement is outside the limits specified, there is a possibility of a shock hazard, and the receiver should be repaired and rechecked before it is returned to the customer.

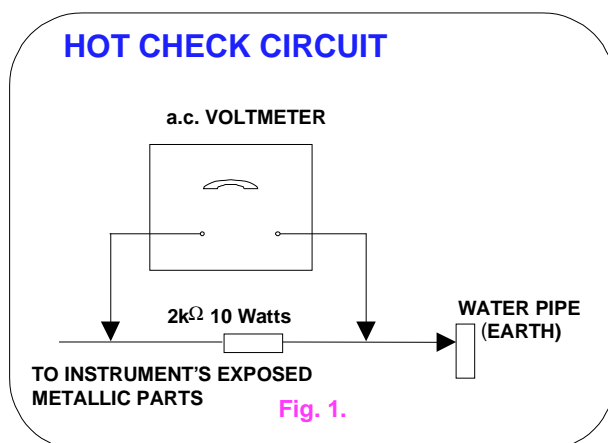

Fig. 1.

### X-RADIATION WARNING

1. The potential sources of X-Radiation in TV sets are the high voltage section and the picture tube.
2. When using a picture tube test jig for service, ensure that the jig is capable of handling 29,2kV {29kV} without causing X-Radiation.

**NOTE:** It is important to use an accurate periodically calibrated high voltage meter.

1. Set the brightness to minimum.
2. Measure the high voltage. The meter should indicate.  

TX-28MK1/M	28,2kV ± 1kV.
TX-21MK1/M	28kV ± 1kV.

If the meter indication is out of tolerance, immediate service and correction is required to prevent the possibility of premature component failure.
3. To prevent any X-Radiation possibility, it is essential to use the specified tube.

## SERVICE HINTS

### How to remove the rear cover

1. Remove the 9 screws as shown in Fig.2.



SCREWS  
Fig.2.

## LOCATION OF CONTROLS

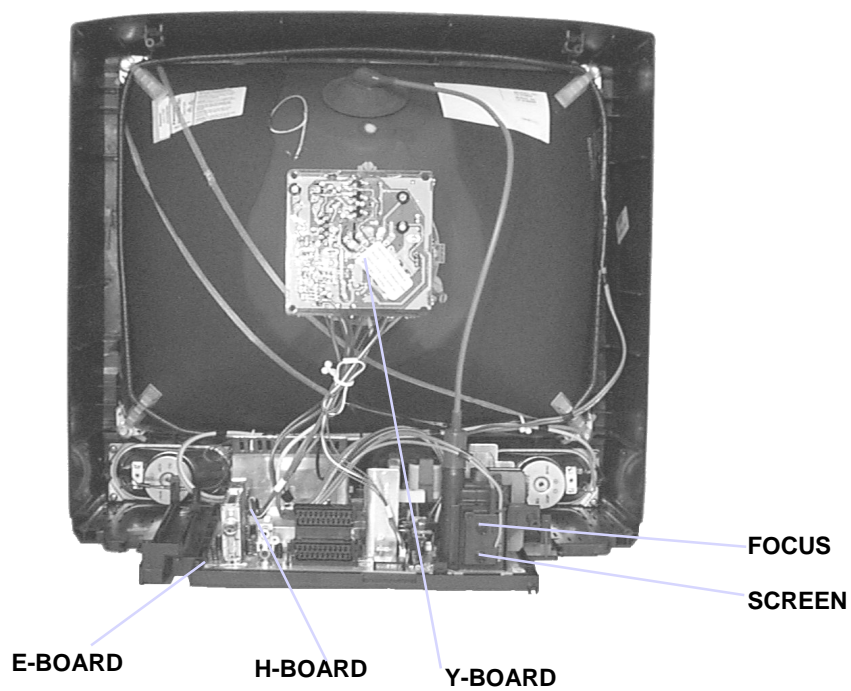

Fig.3.

## HOW TO MOVE THE CHASSIS INTO SERVICE POSITION

1. Remove the bead clumper from the mains lead and attach to the degauss coil, shown in **Fig.5**.
2. Hold and lift the rear of the E-PCB chassis and gently pull the chassis toward you, as shown in **Fig.4**.
3. Release the respective wiring clips and rotate the chassis horizontally through 90°, anti-clockwise.
4. Move the EHT lead around to the left side of the CRT neck.
5. Elevate the front of the chassis.
6. Clip the chassis frame onto the bead clumper, on the degauss coil, as shown in **Fig.5**.
7. Locate the base of the chassis frame into the hole (marked A), shown in **Fig.6**.
8. After servicing replace the bead clumper and ensure all wiring is returned to its original position before returning the receiver to the customer.

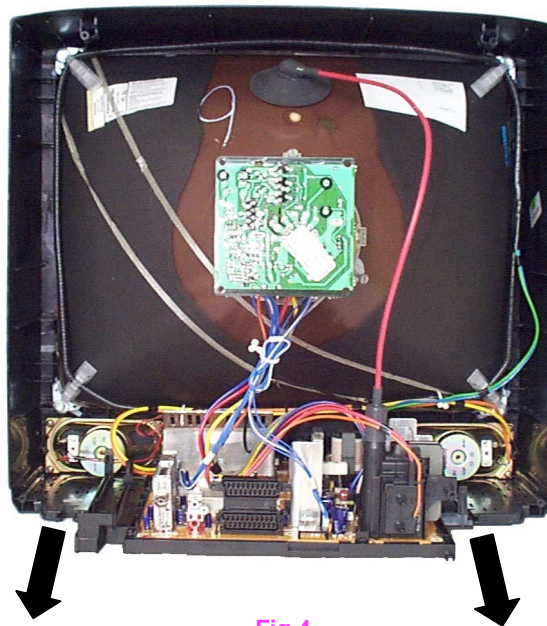

Fig.4.

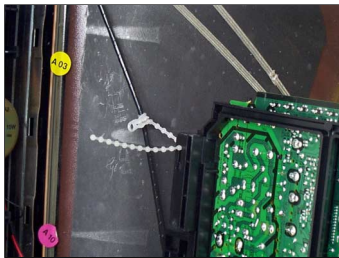

Fig.5.

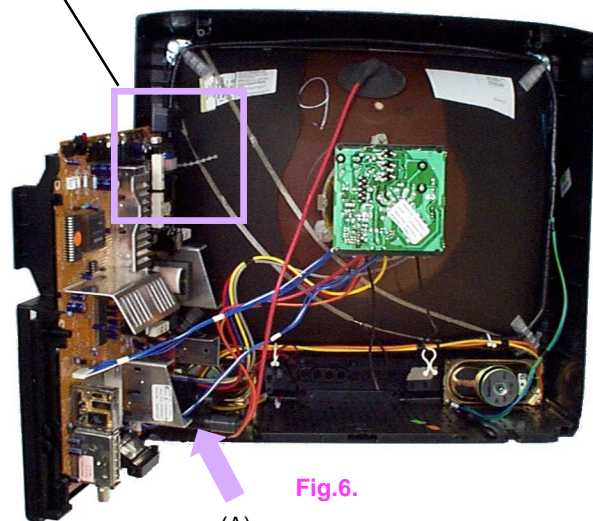



Fig.6.

(A)

## ADJUSTMENT PROCEDURE

Item / Preparation	Adjustments																								
<b>+B SET-UP</b> 1. Receive a Greyscale signal. 2. Set the controls :-  Brightness      Minimum  Contrast        Minimum  Volume          Minimum	1. Set the +B voltage up as follows:- Adjust <b>R811</b> so that <b>B2</b> shows $148V \pm 1V$ { $130V \pm 1V$ TX-21MK1/M} 2. Confirm the following voltages. <table style="width: 100%; border: none;"> <tr> <td><b>B9</b></td> <td>5 ± 0,25V</td> <td><b>B10</b></td> <td>5 ± 0,25V</td> </tr> <tr> <td><b>B5</b></td> <td>12 ± 0,5V</td> <td><b>B11</b></td> <td>33 ± 1,5V</td> </tr> <tr> <td><b>B4</b></td> <td>16 ± 1V</td> <td><b>B7</b></td> <td>8 ± 0,5V</td> </tr> <tr> <td><b>B12</b></td> <td>26 ± 1V</td> <td><b>B8</b></td> <td>5,5 ± 0,5V</td> </tr> <tr> <td><b>B3</b></td> <td>35 ± 1V</td> <td><b>B13</b></td> <td>15 ± 1V</td> </tr> <tr> <td><b>B1</b></td> <td>200 ± 10V</td> <td><b>B14</b></td> <td>-15 ± 1V</td> </tr> </table>	<b>B9</b>	5 ± 0,25V	<b>B10</b>	5 ± 0,25V	<b>B5</b>	12 ± 0,5V	<b>B11</b>	33 ± 1,5V	<b>B4</b>	16 ± 1V	<b>B7</b>	8 ± 0,5V	<b>B12</b>	26 ± 1V	<b>B8</b>	5,5 ± 0,5V	<b>B3</b>	35 ± 1V	<b>B13</b>	15 ± 1V	<b>B1</b>	200 ± 10V	<b>B14</b>	-15 ± 1V
<b>B9</b>	5 ± 0,25V	<b>B10</b>	5 ± 0,25V																						
<b>B5</b>	12 ± 0,5V	<b>B11</b>	33 ± 1,5V																						
<b>B4</b>	16 ± 1V	<b>B7</b>	8 ± 0,5V																						
<b>B12</b>	26 ± 1V	<b>B8</b>	5,5 ± 0,5V																						
<b>B3</b>	35 ± 1V	<b>B13</b>	15 ± 1V																						
<b>B1</b>	200 ± 10V	<b>B14</b>	-15 ± 1V																						
<b>CUT OFF / Ug2 Test</b> 1. Receive a Greyscale signal. 2. Degauss the tube externally. 3. Set the TV into Service Mode 1. 4. Select Cut off mode.	To adjust Cutoff connect an oscilloscope to the Blue cathode, adjust "cutoff" value using the "Yellow" and "Blue" buttons until the black level is $160V \pm 5V$ press " <b>STR</b> " to store the value. Remove the oscilloscope. Select Ug2 adjustment and adjust the screen VR until the display shows "O.K."																								

## FACTORY SETTINGS

To return customer settings to factory settings and clear owner ID of all information input by the customer, enter Self-Check mode. Press the down (-/v) button on the customer controls at the front of the TV set, at the same time pressing the **STATUS** button  on the remote control. To exit Self Check, switch off the TV set at the power button.

**NOTE:** Self Check should only be used when refurbishing the TV set and not during normal repair work.

VDP	O.K.	PCB	O.K.
TUN	O.K.	Cab	O.K.
E2	O.K.	Sum	Factory use only
MSP	O.K.		
DPL	--		
OPTION 1	00 {00}		
OPTION 2	00 {02}		
OPTION 3	02 {02}		
OPTION 4	00 {00}		
OPTION 5	A1 {A1}		
OPTION 6	A9 {A9}		

If the CCU ports have been checked and found to be incorrect or not located then "--" will appear in place of "O.K."

### Service Aids

To aid in the service of our current chassis there are a number of Service Aids which have been made available.

- **LUCI** interface kit (Linked Utility Computer Interface)  
 Part number: TZS6EZ002  
 This contains interface and cables for connecting TV service connector and a PC as well as diagnostic software. As new models are introduced upgrade software will become available.
- **VICI** (Visual Interactive Computer Information)  
 These C.D.'s contain multimedia documentation providing quick access to service information.  
 Part No. TZS7EZ006, TZS7EZ005 & TZS8EZ001
  1. Service Manuals
  2. Instruction Books
  3. Technical Information
- **TASMIN** (Technically Advanced System for Multimedia Interactive Notes)  
 As well as providing a first step towards more interactive training this product also achieves quick access to Technical Information.

## WAVEFORM PATTERN TABLE

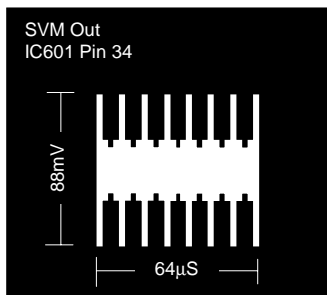
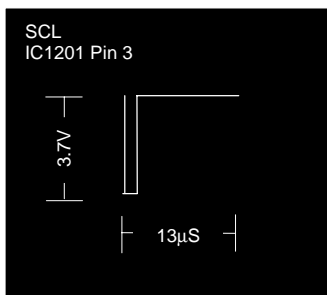
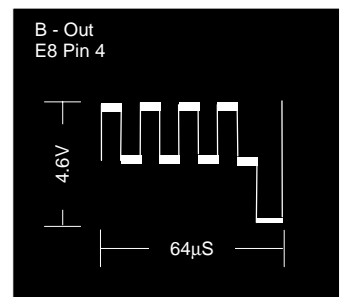
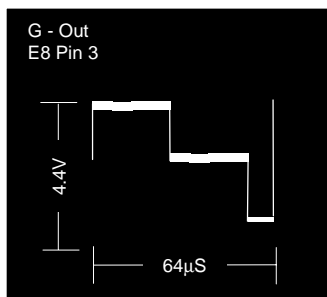
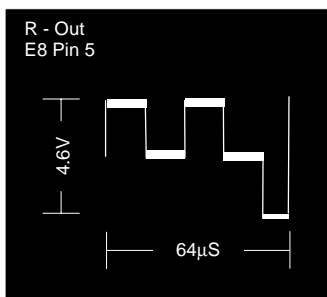
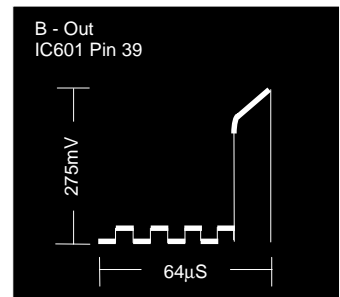
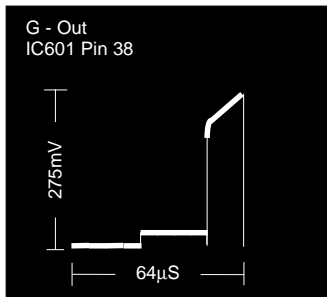
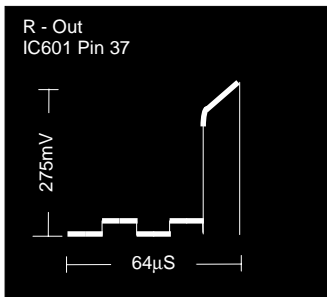
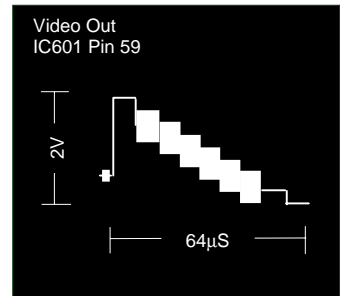
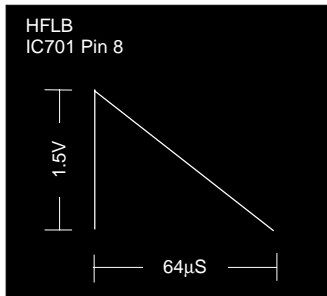
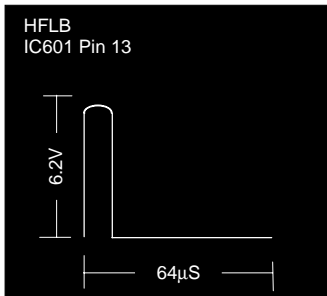
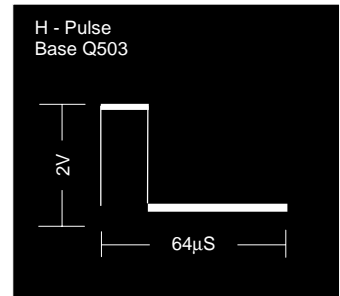
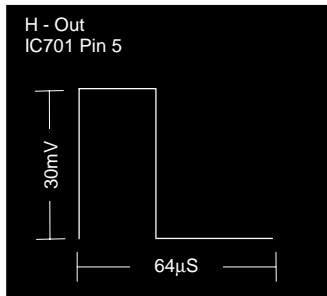
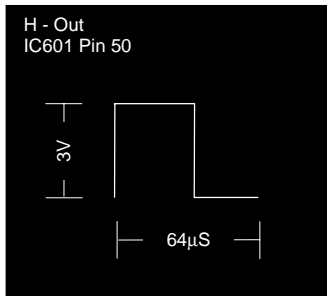
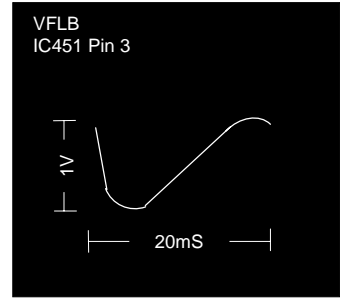
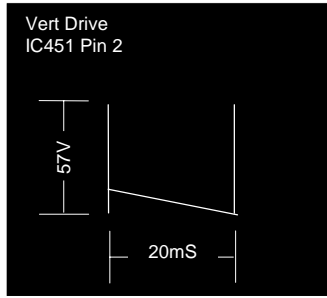
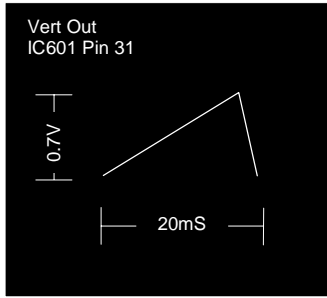

## ALIGNMENT SETTINGS

(The figures below are nominal and used for representative purposes only.)

Alignment Function		Settings / Special features
Horizontal Position	H-Pos 061	Optimum setting.
Vertical Position	V-Pos 005	Optimum setting.
Horizontal Amplitude	H-Amp 055	Optimum setting.
Vert. Amplitude	V-Amp 054	Optimum setting.
EW-amplitude	EW-Amp1 -128	Optimum setting.
EW-amplitude	EW-Amp2 006	Optimum setting.
Trapezium-comp	Trapez-1 047	Optimum setting.
Trapezium-comp	Trapez-2 -128	Optimum setting.
Vertical Linearity	V-Lin 006	Optimum setting.
Vertical Symmetry	V-Sym 002	Optimum setting.
DVCO	DVCO -005	Receive a PAL Colour Bar Pattern. For DVCO alignment press " <b>Blue</b> " button, wait until the colours are changing slowly and press " <b>STR</b> ".
Cut-off DC	Cut-off 0171	To adjust Cutoff connect an oscilloscope to the blue cathode, adjust "cutoff" value using the " <b>Yellow</b> " and " <b>Blue</b> " buttons until the black level is $160V \pm 5V$ press " <b>STR</b> " to store the value. Remove the oscilloscope. Select Ug2 adjustment and adjust the screen VR until the display shows "O.K."
Ug2 Test	Ug2 055 O.K.	
Highlight Lowlight	High 0902 0777 0864 Low 0117 0132 0112	Optimum setting.
Sub-Brightness	Sub-Brightness 255	Optimum setting.

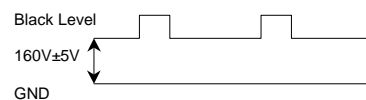



# VIDEO BLOCK DIAGRAM

8

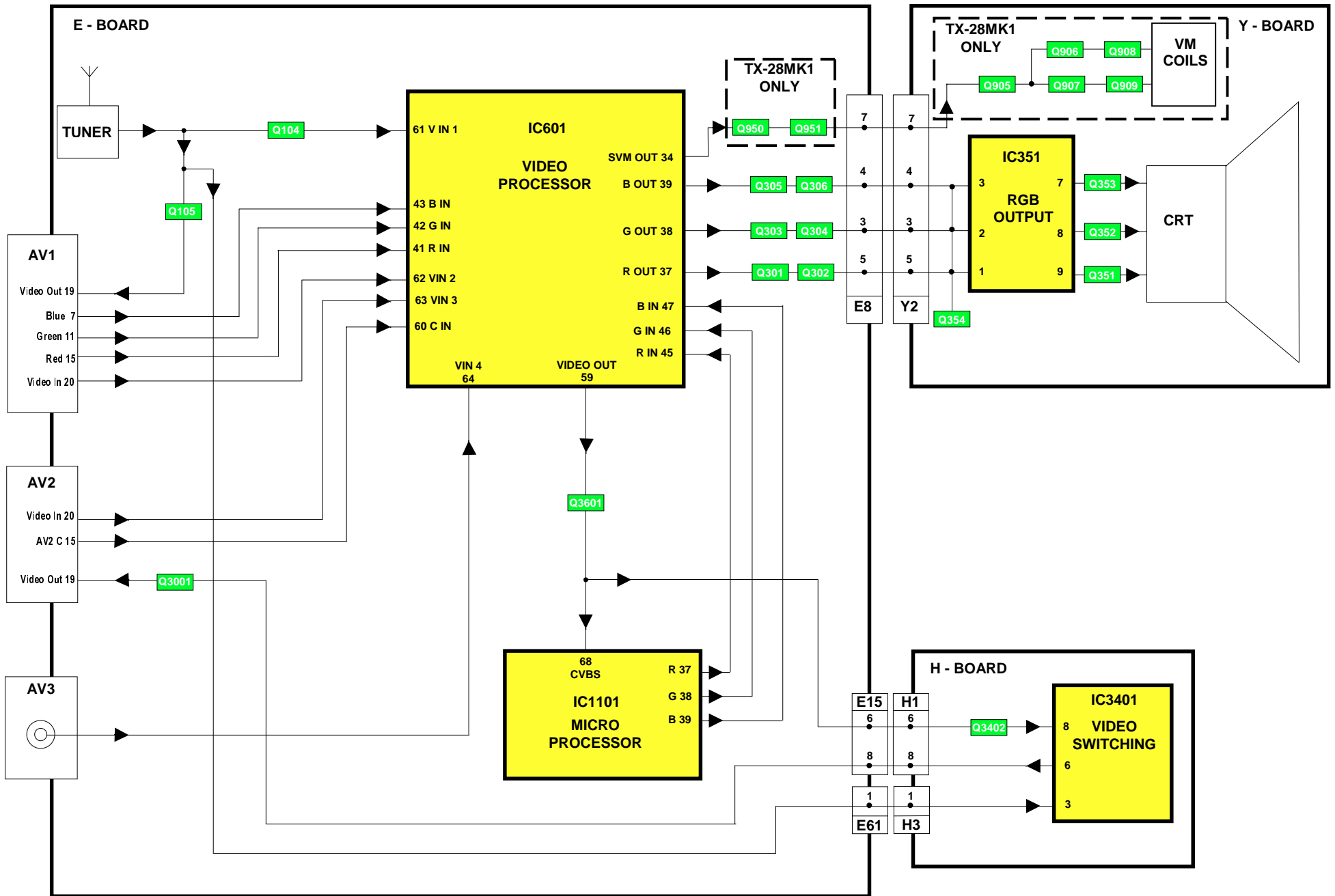

# AUDIO BLOCK DIAGRAM

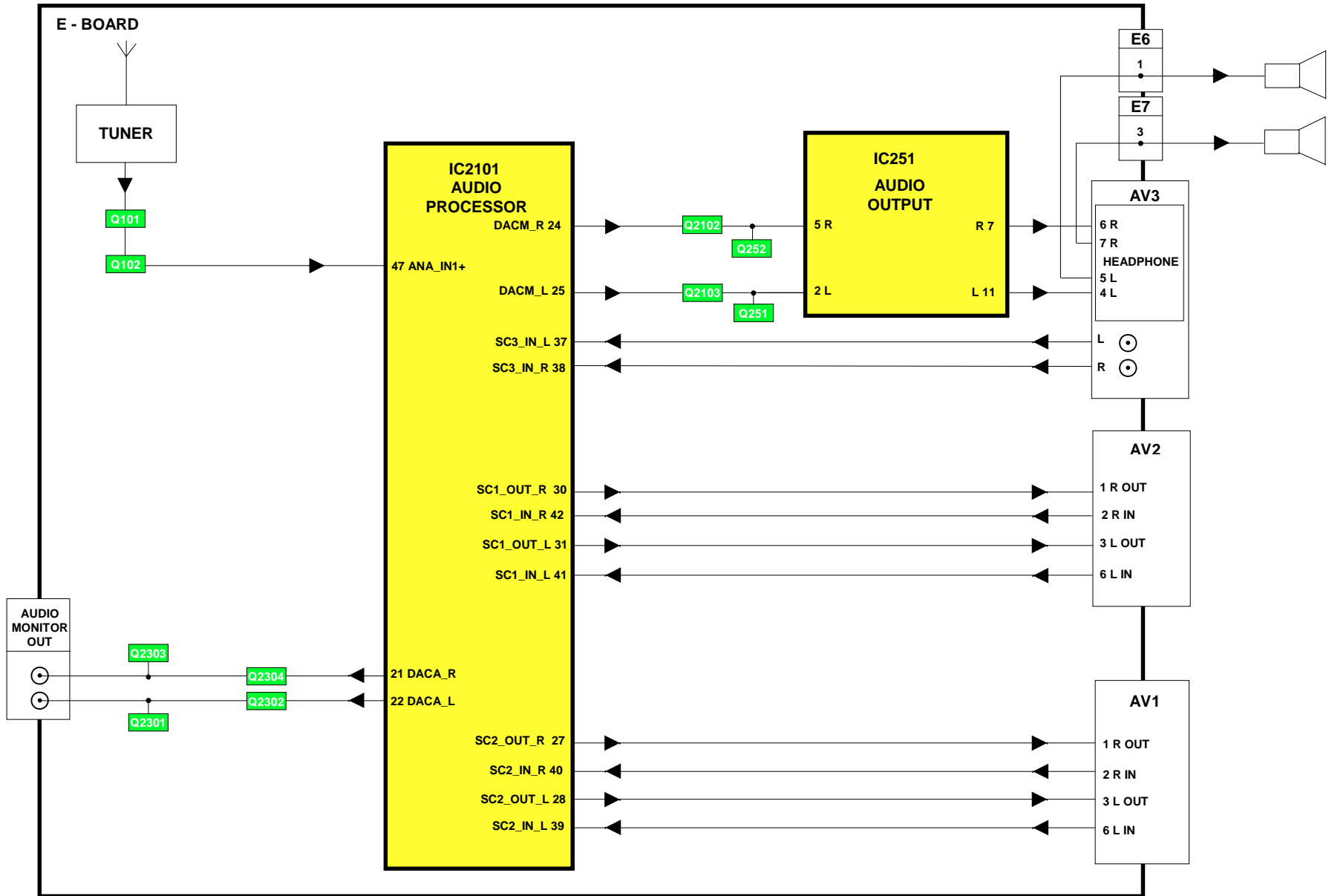

# CONTROL BLOCK DIAGRAM

10

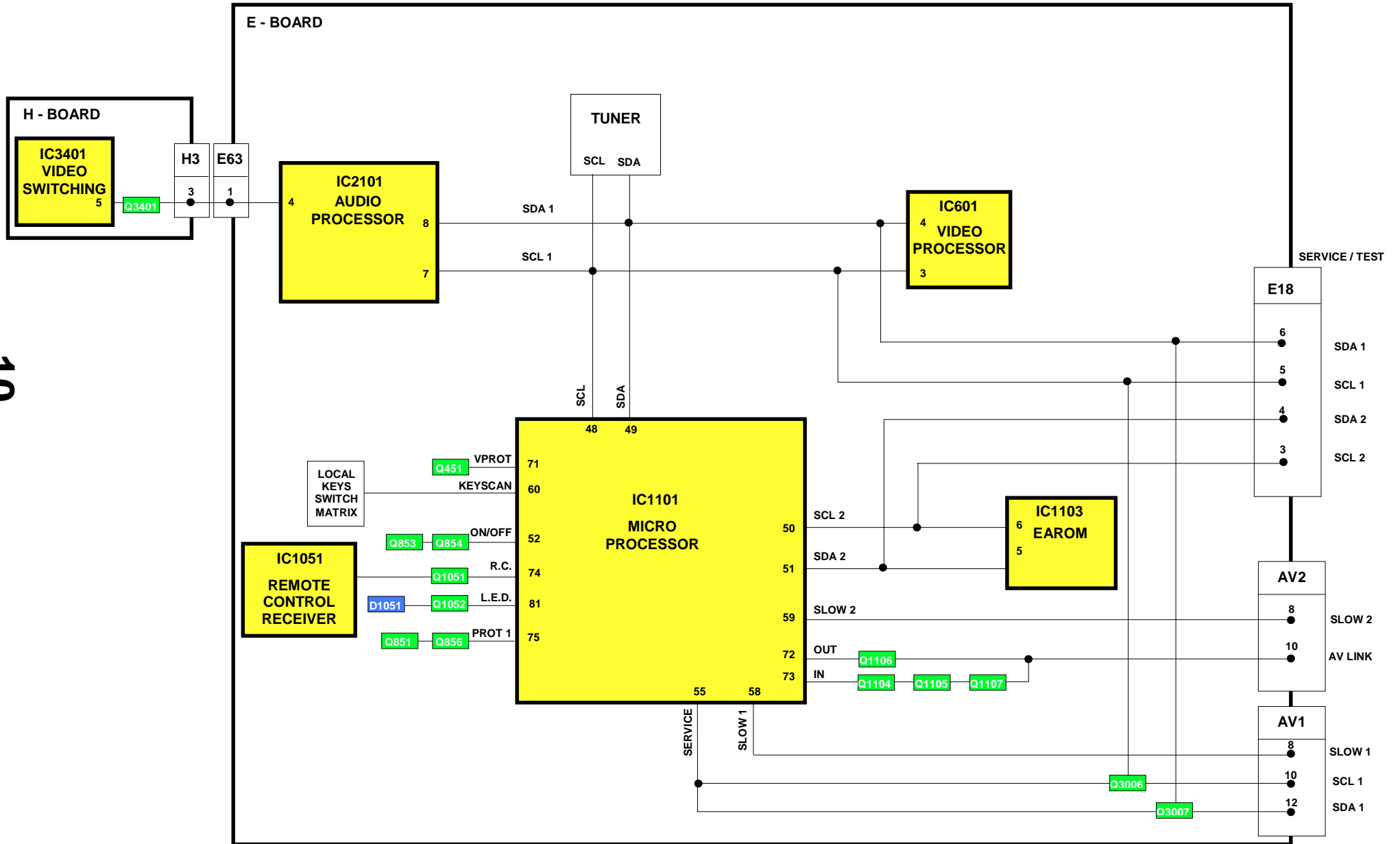

# POWER SUPPLY BLOCK DIAGRAM

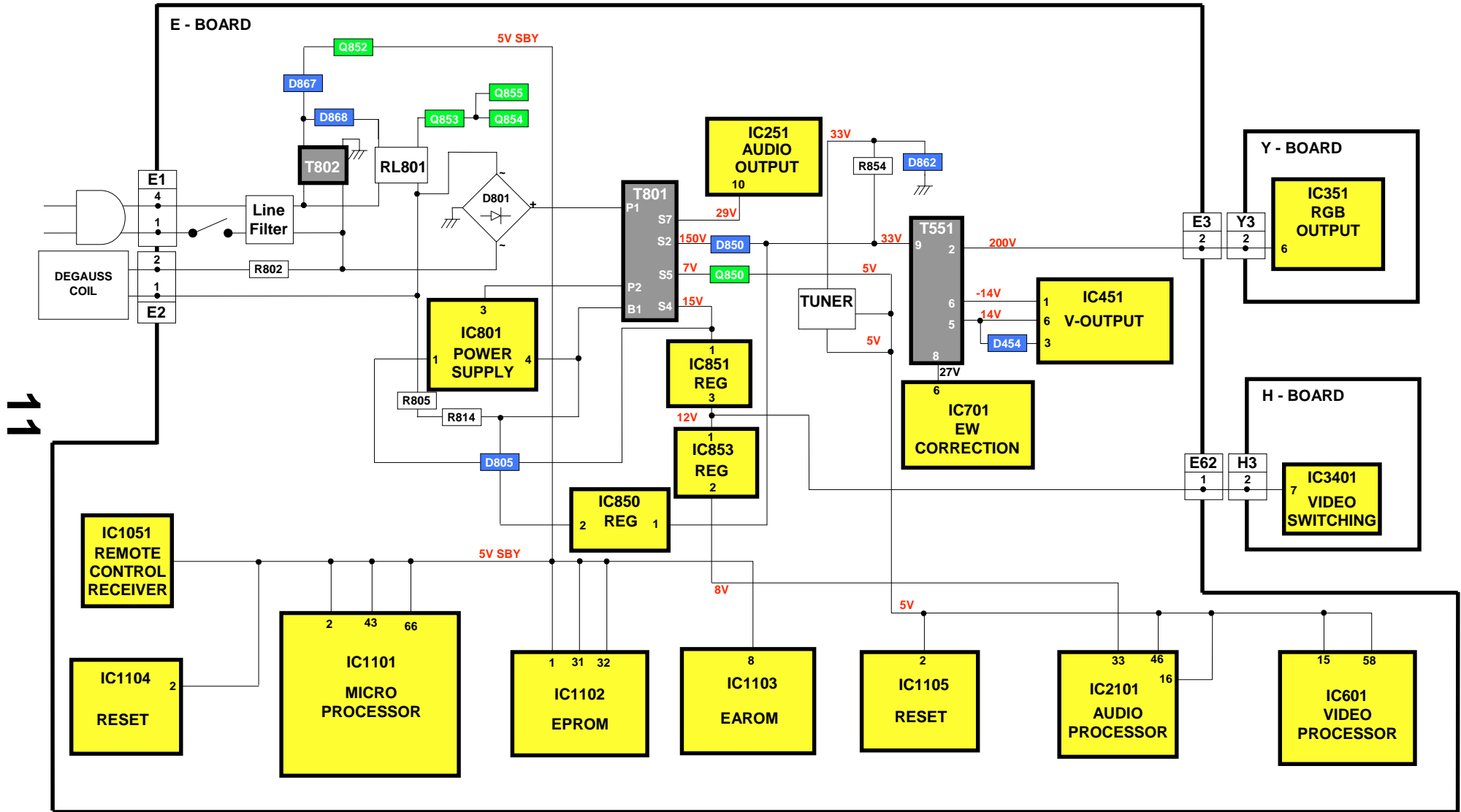

# PARTS LOCATION



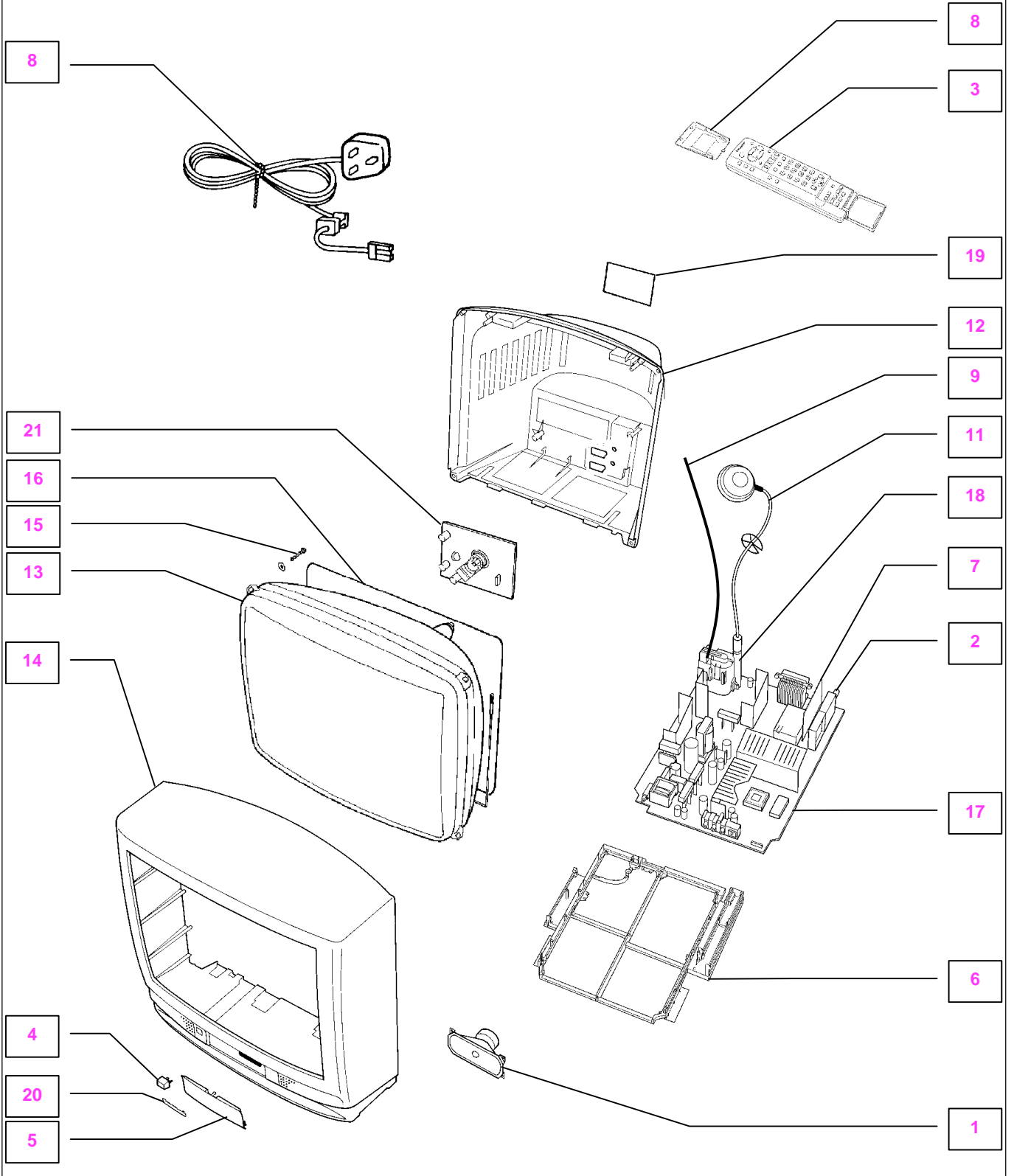

**NOTE:**  
The numbers on the exploded view below refer to the mechanical section of the Replacement Parts List.



# REPLACEMENT PARTS LIST

## Important Safety Notice

Components Identified by  mark have special characteristics important for safety.  
 \* When replacing any of these components, use only manufacturers specified parts.  
 In case of ordering these spare parts, please always add the complete Model-Type number to your order.

Cct Ref	Parts Number	Description
<b>COMMON PARTS</b>		
<b>MECHANICAL PARTS</b>		
1	EASG12D531P2	SPEAKER
2	ENG27506GR	TUNER 
3	EUR511200	REMOTE CONTROL
4	TBX8E069	POWER BUTTON
5	TKP8E1289	LID DOOR
6	TMX8E023	CHASSIS FRAME
7	TNP8EH002AA	H P.C.B. 
8	TSX8E0025	POWER CORD 
9	TXFJTF01BMTG	FOCUS LEAD ASSY
10	UR51EC904A	BATTERY COVER (REMOTE)
<b>MISCELLANEOUS COMPONENTS</b>		
	832AG11D-ESL	IC SOCKET
	F9-4-220	RELAY
	PLCC-84-T	84 PIN IC SOCKET
	TBM8E1920-1	PRE-SET LABEL
	TEK6935	LID SWITCH
	TKP8E1179	LED TUBE
	TKP8E1290	LED VISOR
	TMW8E020-1	LED HOLDER
	TS2800	TV STAND
	UM-3DJ-2P	BATTERY PACK
R802	232266296706	THERMISTOR 
RL801	TSE1885-1	RELAY
S351	0330550049	C.R.T. SOCKET
<b>INSTRUCTION BOOKS</b>		
	TQB8E2704	ENGLISH 
<b>I.C.s</b>		
IC251	LA4282	AUDIO OUTPUT
IC351	TDA6103Q-N3	R.G.B. OUTPUT
IC451	LA7845N	VERTICAL OUTPUT
IC601	VDP3108BPPC2	VIDEO PROCESSOR
IC701	TEA2031A	E/W CORRECTION
IC801	STRF6654LF51	POWER SUPPLY
IC851	L78M12MRB	12V REGULATOR
IC853	AN78L08TA	8V REGULATOR
IC1051	RPM6937-V4	LED RECEIVER
IC1101	SDA5450C48UK	MICRO PROCESSOR
IC1102	27C2001-L03	EPROM *
IC1104	MN1381-R(TA)	RESET
IC1105	MN1381-T(TA)	RESET
IC2101	MSP3410DPOB4	AUDIO PROCESSOR
IC3401	TEA2114	VIDEO SWITCHING

Cct Ref	Parts Number	Description
<b>FUSES</b>		
F802	19181-3.15	FUSE 
F8021	EYF52BC	FUSE HOLDER
F8022	EYF52BC	FUSE HOLDER
<b>DIODES</b>		
D251	MA2180BLFS	DIODE
D253	MA700TA5	DIODE
D254	MA700TA5	DIODE
D354	1SR124-4AT82	DIODE
D355	1SR124-4AT82	DIODE
D356	1SR124-4AT82	DIODE
D357	MA165TA5	DIODE
D358	MA165TA5	DIODE
D359	MA165TA5	DIODE
D360	MTZJT-7715A	DIODE
D361	MA165TA5	DIODE
D362	MA165TA5	DIODE
D363	MA165TA5	DIODE
D364	MA165TA5	DIODE
D453	MA165TA5	DIODE
D454	ERA15-02V3	DIODE
D456	MTZJT-775.6C	DIODE
D457	MA165TA5	DIODE
D501	MA165TA5	DIODE
D502	1SR124-4AT82	DIODE
D511	MA4047	DIODE
D551	ERD07-15L7	DIODE
D552	RU3LFA1	DIODE
D553	1SR124-4AT82	DIODE
D554	1SR124-4AT82	DIODE
D556	MA165TA5	DIODE
D557	EU02	DIODE
D558	1SR124-4AT82	DIODE
D601	DAN217T146	DIODE
D603	DAN217T146	DIODE
D605	DAN212KT146	DIODE
D606	MA165TA5	DIODE
D607	MA4051	DIODE
D609	1SR124-4AT82	DIODE
D615	STZ6.2NT146	DIODE
D616	STZ6.2NT146	DIODE
D701	MA165TA5	DIODE
D801	RBV4-08	DIODE
D803	1SR124-4AT82	DIODE
D804	1SR124-4AT82	DIODE
D805	TLP621GR-LF2	PHOTO COUPLER
D806	1SR124-4AT82	DIODE
D850	RU4BLF-L1	DIODE
D853	MA2180BLFS	DIODE
D854	TVSRU2AMLFA5	DIODE
D855	FML22SLF610	DIODE
D856	RU4AMLF-M1	DIODE

Cct Ref	Parts Number	Description
D857	MTZJT-775.1C	DIODE
D858	MA165TA5	DIODE
D859	MA165TA5	DIODE
D861	MA165TA5	DIODE
D862	MTZJT-7736A	DIODE
D863	MA165TA5	DIODE
D865	MA165TA5	DIODE
D866	MA165TA5	DIODE
D867	EK06-V0	DIODE
D868	1N4150T-77	DIODE
D869	1N4150T-77	DIODE
D870	MA165TA5	DIODE
D871	1N4150T-77	DIODE
D873	MTZJT-775.6C	DIODE
D874	1SR124-4AT82	DIODE
D875	BZX79A75A26A	DIODE
D1051	SLR56UR3FLF	LED
D1101	MA165TA5	DIODE
D1102	MA165TA5	DIODE
D2101	MA723TA5	DIODE
D2102	MA723TA5	DIODE
D2103	MA723TA5	DIODE
D2104	MA723TA5	DIODE
D2105	MTZJT-778.2C	DIODE
D2303	MA723TA5	DIODE
D2304	MA723TA5	DIODE
D3101	MTZJT-778.2C	DIODE
D3102	MTZJT-778.2C	DIODE
<b>TRANSISTORS</b>		
Q101	BC847B	TRANSISTOR
Q102	BC847B	TRANSISTOR
Q104	BC847B	TRANSISTOR
Q105	BC847B	TRANSISTOR
Q251	2SD1328STX	TRANSISTOR
Q252	2SD1328STX	TRANSISTOR
Q253	BC847B	TRANSISTOR
Q254	BC847B	TRANSISTOR
Q301	BC847B	TRANSISTOR
Q302	FMY4T148	TRANSISTOR
Q303	BC847B	TRANSISTOR
Q304	FMY4T148	TRANSISTOR
Q305	BC847B	TRANSISTOR
Q306	FMY4T148	TRANSISTOR
Q354	BC857B	TRANSISTOR
Q451	BC857B	TRANSISTOR
Q503	2SD2398-M2	TRANSISTOR
Q552	2SC1473-RN	TRANSISTOR
Q701	BC857B	TRANSISTOR
Q850	2SD1273PLB	TRANSISTOR
Q851	BC857B	TRANSISTOR
Q852	2SC1383-S	TRANSISTOR
Q853	BC847B	TRANSISTOR
Q854	BC847B	TRANSISTOR
Q855	BC847B	TRANSISTOR
Q856	BC847B	TRANSISTOR
Q857	2SA1018QTA	TRANSISTOR
Q1051	BC847B	TRANSISTOR
Q1052	BC847B	TRANSISTOR
Q1101	BC847B	TRANSISTOR
Q1104	BC847B	TRANSISTOR
Q1105	BC847B	TRANSISTOR
Q1106	BC847B	TRANSISTOR
Q1107	BC847B	TRANSISTOR
Q1108	BC847B	TRANSISTOR
Q2101	BC857B	TRANSISTOR
Q2102	BC857B	TRANSISTOR

Cct Ref	Parts Number	Description
Q2103	BC857B	TRANSISTOR
Q2301	BC847B	TRANSISTOR
Q2302	BC857B	TRANSISTOR
Q2303	BC847B	TRANSISTOR
Q2304	BC857B	TRANSISTOR
Q3001	BC847B	TRANSISTOR
Q3006	BC847B	TRANSISTOR
Q3007	BC847B	TRANSISTOR
Q3401	BC847B	TRANSISTOR
Q3402	BC847B	TRANSISTOR
Q3601	BC847B	TRANSISTOR
<b>TRANSFORMERS</b>		
T501	ETH19Y173AY	TRANSFORMER
T802	ETP35KAN619U	TRANSFORMER
<b>COILS</b>		
L104	EXCELSA35T	COIL
L106	TLTACT100K	COIL
L107	TLTACT6R8K	COIL
L301	TLTACT4R7K	COIL
L302	TLTACT4R7K	COIL
L451	EXCELSA35T	COIL
L501	EXCELSA35T	COIL
L553	ELC08D682E	COIL
L601	TLTACT4R7K	COIL
L602	TLTACT4R7K	COIL
L603	TLTACT4R7K	COIL
L604	TLTACT4R7K	COIL
L606	TLTACT4R7K	COIL
L607	ELJFC2R2KF	COIL
L701	ELC10D822E	COIL
L850	EXCELSA35T	COIL
L851	EXCELSA35T	COIL
L852	ELEIE470KA	COIL
L853	EXCELSA35T	COIL
L854	EXCELSA35T	COIL
L855	EXCELSA35T	COIL
L856	EXCELSA39V	COIL
L1103	TLTACT100K	COIL
L1104	EXCELSA35T	COIL
L1105	ELJFC2R2KF	COIL
L2101	TLTACT100K	COIL
L2103	EXCELSA35T	COIL
L2104	TLTACT4R7K	COIL
L3001	ELEMV1R5MA	COIL
L3002	ELEMV1R5MA	COIL
L3003	ELEMV1R5MA	COIL
L3004	ELEMV1R5MA	COIL
L3005	ELEBR2R2KA	COIL
L3006	ELEBR2R2KA	COIL
L3007	TLTACT2R2K	COIL
L3101	ELEBT6R8KA	COIL
L3102	ELEBT6R8KA	COIL
L3401	ELESN2R2KA	COIL
L3402	ELESN2R2KA	COIL
<b>CRYSTALS</b>		
X601	4730007267	CRYSTAL
X1101	TSSA121	CRYSTAL
X2101	4730007158	CRYSTAL
<b>RESISTORS</b>		
C101	ERJ6GEY0R00	S.M.CARB 0.1W 5% 0 Ω
JA1	ERJ8GEY0R00	S.M.CARB .125W 5% 0 Ω
JA2	ERJ8GEY0R00	S.M.CARB .125W 5% 0 Ω
JA5	ERJ8GEY0R00	S.M.CARB .125W 5% 0 Ω
JA8	ERJ8GEY0R00	S.M.CARB .125W 5% 0 Ω
JA9	ERJ6GEY0R00	S.M.CARB 0.1W 5% 0 Ω

Cct Ref	Parts Number	Description			
JA10	ERJ6GEY0R00	S.M.CARB	0.1W	5%	0 Ω
JA11	ERJ6GEY0R00	S.M.CARB	0.1W	5%	0 Ω
JA12	ERJ6GEY0R00	S.M.CARB	0.1W	5%	0 Ω
JA13	ERJ6GEY0R00	S.M.CARB	0.1W	5%	0 Ω
JA14	ERJ6GEY0R00	S.M.CARB	0.1W	5%	0 Ω
JA15	ERJ6GEY0R00	S.M.CARB	0.1W	5%	0 Ω
JA16	ERJ6GEY0R00	S.M.CARB	0.1W	5%	0 Ω
JA17	ERJ6GEY0R00	S.M.CARB	0.1W	5%	0 Ω
JA18	ERJ8GEY0R00	S.M.CARB	.125W	5%	0 Ω
JA21	ERJ8GEY0R00	S.M.CARB	.125W	5%	0 Ω
JA22	ERJ6GEY0R00	S.M.CARB	0.1W	5%	0 Ω
JA23	ERJ8GEY0R00	S.M.CARB	.125W	5%	0 Ω
JA25	ERJ6GEY0R00	S.M.CARB	0.1W	5%	0 Ω
JA26	ERJ6GEY0R00	S.M.CARB	0.1W	5%	0 Ω
JA27	ERJ6GEY0R00	S.M.CARB	0.1W	5%	0 Ω
JA28	ERJ6GEY0R00	S.M.CARB	0.1W	5%	0 Ω
JA29	ERJ8GEY0R00	S.M.CARB	.125W	5%	0 Ω
JA30	ERJ8GEY0R00	S.M.CARB	.125W	5%	0 Ω
JA31	ERJ8GEY0R00	S.M.CARB	.125W	5%	0 Ω
JA32	ERJ8GEY0R00	S.M.CARB	.125W	5%	0 Ω
JA33	ERJ8GEY0R00	S.M.CARB	.125W	5%	0 Ω
JA34	ERJ8GEY0R00	S.M.CARB	.125W	5%	0 Ω
JA35	ERJ8GEY0R00	S.M.CARB	.125W	5%	0 Ω
JA36	ERJ6GEY0R00	S.M.CARB	0.1W	5%	0 Ω
JA37	ERJ6GEY0R00	S.M.CARB	0.1W	5%	0 Ω
JA38	ERJ6GEY0R00	S.M.CARB	0.1W	5%	0 Ω
JA39	ERJ6GEY0R00	S.M.CARB	0.1W	5%	0 Ω
JA40	ERJ6GEY0R00	S.M.CARB	0.1W	5%	0 Ω
JA43	ERJ8GEY0R00	S.M.CARB	.125W	5%	0 Ω
JA44	ERJ6GEY0R00	S.M.CARB	0.1W	5%	0 Ω
JA45	ERJ6GEY0R00	S.M.CARB	0.1W	5%	0 Ω
JA46	ERJ8GEY0R00	S.M.CARB	.125W	5%	0 Ω
JA47	ERJ6GEY0R00	S.M.CARB	0.1W	5%	0 Ω
JA48	ERJ6GEY0R00	S.M.CARB	0.1W	5%	0 Ω
JA49	ERJ6GEY0R00	S.M.CARB	0.1W	5%	0 Ω
JA50	ERJ8GEY0R00	S.M.CARB	.125W	5%	0 Ω
JA51	ERJ8GEY0R00	S.M.CARB	.125W	5%	0 Ω
JA52	ERJ6GEY0R00	S.M.CARB	0.1W	5%	0 Ω
JA53	ERJ8GEY0R00	S.M.CARB	.125W	5%	0 Ω
JA54	ERJ6GEY0R00	S.M.CARB	0.1W	5%	0 Ω
JA55	ERJ6GEY0R00	S.M.CARB	0.1W	5%	0 Ω
JA56	ERJ8GEY0R00	S.M.CARB	.125W	5%	0 Ω
JA57	ERJ6GEY0R00	S.M.CARB	0.1W	5%	0 Ω
JA58	ERJ6GEY0R00	S.M.CARB	0.1W	5%	0 Ω
JA59	ERJ8GEY0R00	S.M.CARB	.125W	5%	0 Ω
JA60	ERJ6GEY0R00	S.M.CARB	0.1W	5%	0 Ω
JA61	ERJ8GEY0R00	S.M.CARB	.125W	5%	0 Ω
JSE3	ERJ6GEY0R00	S.M.CARB	0.1W	5%	0 Ω
JSE4	ERJ6GEY0R00	S.M.CARB	0.1W	5%	0 Ω
JSE5	ERJ6GEY0R00	S.M.CARB	0.1W	5%	0 Ω
JSE10	ERJ6GEY0R00	S.M.CARB	0.1W	5%	0 Ω
JSE12	ERJ6GEY0R00	S.M.CARB	0.1W	5%	0 Ω
JSE18	ERJ6GEY0R00	S.M.CARB	0.1W	5%	0 Ω
JSE22	ERJ6GEY0R00	S.M.CARB	0.1W	5%	0 Ω
JSE26	ERJ6GEY0R00	S.M.CARB	0.1W	5%	0 Ω
JSE33	ERJ6GEY0R00	S.M.CARB	0.1W	5%	0 Ω
JSE35	ERJ6GEY0R00	S.M.CARB	0.1W	5%	0 Ω
JSE43	ERJ6GEY0R00	S.M.CARB	0.1W	5%	0 Ω
JSE45	ERJ8GEY0R00	S.M.CARB	.125W	5%	0 Ω
JSE46	ERJ8GEY0R00	S.M.CARB	.125W	5%	0 Ω
JSE47	ERJ8GEY0R00	S.M.CARB	.125W	5%	0 Ω
JSH001	ERJ6GEY0R00	S.M.CARB	0.1W	5%	0 Ω
R101	ERJ6GEY0R00	S.M.CARB	0.1W	5%	0 Ω
R102	ERJ6GEYJ103	S.M.CARB	0.1W	5%	10K Ω
R103	ERJ6GEYJ222	S.M.CARB	0.1W	5%	2K2 Ω
R104	ERJ6GEYJ332	S.M.CARB	0.1W	5%	3K3 Ω

Cct Ref	Parts Number	Description			
R105	ERJ6GEYJ101	S.M.CARB	0.1W	5%	100 Ω
R106	ERJ6GEYJ681	S.M.CARB	0.1W	5%	680 Ω
R107	ERJ6GEYJ102	S.M.CARB	0.1W	5%	1K Ω
R111	ERJ6GEY0R00	S.M.CARB	0.1W	5%	0 Ω
R112	ERJ6GEYJ101	S.M.CARB	0.1W	5%	100 Ω
R113	ERJ6GEYJ223	S.M.CARB	0.1W	5%	22K Ω
R114	ERJ6GEYJ331	S.M.CARB	0.1W	5%	330 Ω
R115	ERJ6GEYJ331	S.M.CARB	0.1W	5%	330 Ω
R116	ERJ6GEYJ562	S.M.CARB	0.1W	5%	5K6 Ω
R117	ERJ6GEYJ222	S.M.CARB	0.1W	5%	2K2 Ω
R118	ERJ6GEYJ102	S.M.CARB	0.1W	5%	1K Ω
R121	ERJ6GEYJ471	S.M.CARB	0.1W	5%	470 Ω
R251	ERJ6GEYJ101	S.M.CARB	0.1W	5%	100 Ω
R253	ERJ6GEYJ103	S.M.CARB	0.1W	5%	10K Ω
R254	ERJ6GEYJ101	S.M.CARB	0.1W	5%	100 Ω
R255	ERJ6GEYJ103	S.M.CARB	0.1W	5%	10K Ω
R256	ERJ6GEYJ471	S.M.CARB	0.1W	5%	470 Ω
R260	ERJ6GEYJ103	S.M.CARB	0.1W	5%	10K Ω
R261	ERJ6GEYJ471	S.M.CARB	0.1W	5%	470 Ω
R262	ERJ6GEYJ103	S.M.CARB	0.1W	5%	10K Ω
R263	ERJ6GEYJ473	S.M.CARB	0.1W	5%	47K Ω
R264	ERJ6GEYJ103	S.M.CARB	0.1W	5%	10K Ω
R265	ERD25TJ2R2	CARBON	0.25W	5%	2R2 Ω
R266	ERD25TJ2R2	CARBON	0.25W	5%	2R2 Ω
R267	ERF7ZK4R7	WOUND	7W	10%	4R7 Ω
R268	ERJ6GEYJ103	S.M.CARB	0.1W	5%	10K Ω
R269	ERQ14AJ101	METAL	0.25W	5%	100 Ω
R271	ERJ6GEYJ103	S.M.CARB	0.1W	5%	10K Ω
R272	ERF7ZK4R7	WOUND	7W	10%	4R7 Ω
R301	ERJ6GEYJ391	S.M.CARB	0.1W	5%	390 Ω
R302	ERJ6GEYJ102	S.M.CARB	0.1W	5%	1K Ω
R303	ERJ6GEYJ750	S.M.CARB	0.1W	5%	75 Ω
R304	ERJ6GEYJ331	S.M.CARB	0.1W	5%	330 Ω
R305	ERJ6GEYJ391	S.M.CARB	0.1W	5%	390 Ω
R306	ERJ6GEYJ102	S.M.CARB	0.1W	5%	1K Ω
R307	ERJ6GEYJ750	S.M.CARB	0.1W	5%	75 Ω
R308	ERJ6GEYJ331	S.M.CARB	0.1W	5%	330 Ω
R309	ERJ6GEYJ391	S.M.CARB	0.1W	5%	390 Ω
R310	ERJ6GEYJ102	S.M.CARB	0.1W	5%	1K Ω
R311	ERJ6GEYJ750	S.M.CARB	0.1W	5%	75 Ω
R312	ERJ6GEYJ331	S.M.CARB	0.1W	5%	330 Ω
R351	ERJ6GEYJ302	S.M.CARB	0.1W	5%	3K Ω
R352	ERJ6GEYJ302	S.M.CARB	0.1W	5%	3K Ω
R353	ERJ6GEYJ302	S.M.CARB	0.1W	5%	3K Ω
R354	ERJ6GEYJ102	S.M.CARB	0.1W	5%	1K Ω
R355	ERJ6GEYJ102	S.M.CARB	0.1W	5%	1K Ω
R356	ERJ6GEYJ102	S.M.CARB	0.1W	5%	1K Ω
R366	ERDS1TJ152	CARBON	0.5W	5%	1K5 Ω
R367	ERDS1TJ152	CARBON	0.5W	5%	1K5 Ω
R368	ERDS1TJ152	CARBON	0.5W	5%	1K5 Ω
R372	ERQ12AJ121	FUSIBLE	0.5W	5%	120 Ω
R373	ERJ6GEYJ220	S.M.CARB	0.1W	5%	22 Ω
R374	ERD25TJ274	CARBON	0.25W	5%	270K Ω
R375	ERJ6GEYJ684	S.M.CARB	0.1W	5%	680K Ω
R376	ERJ6GEYJ183	S.M.CARB	0.1W	5%	18K Ω
R378	ERJ6GEY0R00	S.M.CARB	0.1W	5%	0 Ω
R379	ERJ6GEY0R00	S.M.CARB	0.1W	5%	0 Ω
R380	ERJ6GEY0R00	S.M.CARB	0.1W	5%	0 Ω
R381	ERJ6GEYJ473	S.M.CARB	0.1W	5%	47K Ω
R451	ERJ6GEYJ223	S.M.CARB	0.1W	5%	22K Ω
R452	ERJ6GEY0R00	S.M.CARB	0.1W	5%	0 Ω
R453	ERJ6GEY0R00	S.M.CARB	0.1W	5%	0 Ω
R454	ERJ6GEYJ752	S.M.CARB	0.1W	5%	7K5 Ω
R455	ERJ6GEYJ222	S.M.CARB	0.1W	5%	2K2 Ω
R456	ERJ6GEYJ104	S.M.CARB	0.1W	5%	100K Ω
R457	ERJ6GEYJ223	S.M.CARB	0.1W	5%	22K Ω



Cct Ref	Parts Number	Description				
R458	ERD25TJ1R5	CARBON	0.25W	5%	1R5 Ω	
R459	ERJ6GEYJ101	S.M.CARB	0.1W	5%	100 Ω	
R460	ERDS1TJ331	CARBON	0.5W	5%	330 Ω	
R463	ERD25TJ222	CARBON	0.25W	5%	2K2 Ω	
R464	ERJ6GEYJ182	S.M.CARB	0.1W	5%	1K8 Ω	
R465	ERJ6GEYJ681	S.M.CARB	0.1W	5%	680 Ω	
R502	ERJ6GEYJ511	S.M.CARB	0.1W	5%	510 Ω	
R506	ERD25TJ560	CARBON	0.25W	5%	56 Ω	
R509	ERDS1TJ152	CARBON	0.5W	5%	1K5 Ω	
R510	ERDS1FJ152	CARBON	0.5W	5%	1K5 Ω	△
R553	ERG1SJ152	METAL	1W	5%	1K5 Ω	
R554	ERG1SJ101	METAL	1W	5%	100 Ω	
R558	ERDS1TJ124	CARBON	0.5W	5%	120K Ω	
R559	ERQ12HHR33	METAL	0.5W	5%	R33 Ω	△
R560	ERJ6GEYJ274	S.M.CARB	0.1W	5%	270K Ω	
R561	ERJ6GEYJ273	S.M.CARB	0.1W	5%	27K Ω	
R566	ERJ6GEYJ563	S.M.CARB	0.1W	5%	56K Ω	
R601	ERJ6GEYJ101	S.M.CARB	0.1W	5%	100 Ω	
R602	ERJ6GEYJ821	S.M.CARB	0.1W	5%	820 Ω	
R603	ERJ8GEYJ103	S.M.CARB	.125W	5%	10K Ω	
R604	ERJ6GEYJ101	S.M.CARB	0.1W	5%	100 Ω	
R605	ERD25TJ331	CARBON	0.25W	5%	330 Ω	
R606	ERD25TJ331	CARBON	0.25W	5%	330 Ω	
R607	ERJ6GEYJ821	S.M.CARB	0.1W	5%	820 Ω	
R608	ERJ6GEYJ271	S.M.CARB	0.1W	5%	270 Ω	
R609	ERJ6GEYJ122	S.M.CARB	0.1W	5%	1K2 Ω	
R610	ERJ6GEY0R00	S.M.CARB	0.1W	5%	0 Ω	
R611	ERJ6GEYJ103	S.M.CARB	0.1W	5%	10K Ω	
R612	ERJ6GEYJ101	S.M.CARB	0.1W	5%	100 Ω	
R613	ERJ6GEYJ152	S.M.CARB	0.1W	5%	1K5 Ω	
R622	ERJ6GEY0R00	S.M.CARB	0.1W	5%	0 Ω	
R636	ERJ6GEYJ750	S.M.CARB	0.1W	5%	75 Ω	
R645	ERJ6GEYJ103	S.M.CARB	0.1W	5%	10K Ω	
R647	ERJ6GEYJ472	S.M.CARB	0.1W	5%	4K7 Ω	
R648	ERJ6GEYJ152	S.M.CARB	0.1W	5%	1K5 Ω	
R650	ERJ6GEYJ750	S.M.CARB	0.1W	5%	75 Ω	
R651	ERJ6GEYJ750	S.M.CARB	0.1W	5%	75 Ω	
R652	ERJ6GEYJ102	S.M.CARB	0.1W	5%	1K Ω	
R654	ERJ6GEYJ622	S.M.CARB	0.1W	5%	6K2 Ω	
R655	ERJ6GEYJ103	S.M.CARB	0.1W	5%	10K Ω	
R658	ERJ6GEYJ153	S.M.CARB	0.1W	5%	15K Ω	
R659	ERJ6GEY0R00	S.M.CARB	0.1W	5%	0 Ω	
R660	ERJ6GEY0R00	S.M.CARB	0.1W	5%	0 Ω	
R701	ERQ12AJ101	FUSIBLE	0.5W	5%	100 Ω	△
R702	ERQ12HJ8R2	FUSIBLE	0.5W	5%	8R2 Ω	△
R703	ERG2FJ821	METAL	2W	5%	820 Ω	△
R704	ERJ6GEYJ563	S.M.CARB	0.1W	5%	56K Ω	
R705	ERJ6GEYJ104	S.M.CARB	0.1W	5%	100K Ω	
R708	ERJ6GEYJ393	S.M.CARB	0.1W	5%	39K Ω	
R709	ERJ6GEYJ393	S.M.CARB	0.1W	5%	39K Ω	
R710	ERJ6GEYJ273	S.M.CARB	0.1W	5%	27K Ω	
R711	ERG1SJ101	METAL	1W	5%	100 Ω	
R803	ERC12ZGK335D	SOLID	0.5W	10%	3M3 Ω	
R805	ERD25TJ473	CARBON	0.25W	5%	47K Ω	
R806	ERD25TJ100	CARBON	0.25W	5%	10 Ω	
R807	ERD25TJ332	CARBON	0.25W	5%	3K3 Ω	
R809	ERD25TJ681	CARBON	0.25W	5%	680 Ω	
R811	ERW2PKR33	WOUND	2W	20%	R33 Ω	△
R812	ERD75TAJ825	CARBON	0.75W	5%	8M2 Ω	△
R813	ERF7ZK2R7	WOUND	7W	20%	2R7 Ω	△
R814	ERD25TJ473	CARBON	0.25W	5%	47K Ω	
R815	ERD25TJ222	CARBON	0.25W	5%	2K2 Ω	
R850	ERD25TJ122	CARBON	0.25W	5%	1K2 Ω	
R852	ERJ6GEY0R00	S.M.CARB	0.1W	5%	0 Ω	
R853	ERJ6GEYJ102	S.M.CARB	0.1W	5%	1K Ω	
R854	ERG2FJ223	METAL	2W	5%	22K Ω	△

Cct Ref	Parts Number	Description				
R855	ERJ6GEYJ752	S.M.CARB	0.1W	5%	7K5 Ω	
R857	ERJ6GEYJ752	S.M.CARB	0.1W	5%	7K5 Ω	
R858	ERJ6GEYJ752	S.M.CARB	0.1W	5%	7K5 Ω	
R859	ERJ6GEYJ753	S.M.CARB	0.1W	5%	75K Ω	
R860	ERQ1CJP2R2	FUSIBLE	1W	10%	2R2 Ω	△
R861	ERD25TJ221	CARBON	0.25W	5%	220 Ω	
R862	ERD25TJ272	CARBON	0.25W	5%	2K7 Ω	
R863	ERDS1TJ560	CARBON	0.5W	5%	56 Ω	
R864	ERDS1TJ680	CARBON	0.5W	5%	68 Ω	
R865	ERJ6GEY0R00	S.M.CARB	0.1W	5%	0 Ω	
R867	ERJ6GEYJ103	S.M.CARB	0.1W	5%	10K Ω	
R868	ERJ6GEYJ223	S.M.CARB	0.1W	5%	22K Ω	
R869	ERJ6GEY0R00	S.M.CARB	0.1W	5%	0 Ω	
R870	ERJ6GEYJ272	S.M.CARB	0.1W	5%	2K7 Ω	
R871	ERJ6GEYJ153	S.M.CARB	0.1W	5%	15K Ω	
R872	ERG1SJ183	METAL	1W	5%	18K Ω	
R873	ERG1SJ223	METAL	1W	5%	22K Ω	
R874	ERD25TJ104	CARBON	0.25W	5%	100K Ω	
R876	ERJ6GEYJ103	S.M.CARB	0.1W	5%	10K Ω	
R877	ERW2PKR56	WOUND	2W	10%	R56 Ω	△
R878	ERJ6GEYJ473	S.M.CARB	0.1W	5%	47K Ω	
R1051	ERJ6GEYJ102	S.M.CARB	0.1W	5%	1K Ω	
R1052	ERJ6GEYJ271	S.M.CARB	0.1W	5%	270 Ω	
R1053	ERJ6GEYJ103	S.M.CARB	0.1W	5%	10K Ω	
R1054	ERJ6GEYJ750	S.M.CARB	0.1W	5%	75 Ω	
R1101	ERJ6GEYJ101	S.M.CARB	0.1W	5%	100 Ω	
R1102	ERJ6GEYJ102	S.M.CARB	0.1W	5%	1K Ω	
R1103	ERJ6GEYJ331	S.M.CARB	0.1W	5%	330 Ω	
R1104	ERJ6GEYJ331	S.M.CARB	0.1W	5%	330 Ω	
R1105	ERJ6GEYJ101	S.M.CARB	0.1W	5%	100 Ω	
R1106	ERJ6GEYJ104	S.M.CARB	0.1W	5%	100K Ω	
R1107	ERJ6GEYJ104	S.M.CARB	0.1W	5%	100K Ω	
R1108	ERJ6GEYJ102	S.M.CARB	0.1W	5%	1K Ω	
R1109	ERJ6GEYJ472	S.M.CARB	0.1W	5%	4K7 Ω	
R1110	ERJ6GEYJ472	S.M.CARB	0.1W	5%	4K7 Ω	
R1111	ERJ6GEYJ473	S.M.CARB	0.1W	5%	47K Ω	
R1112	ERJ6GEYJ473	S.M.CARB	0.1W	5%	47K Ω	
R1113	ERJ6GEYJ101	S.M.CARB	0.1W	5%	100 Ω	
R1115	ERJ6GEYJ471	S.M.CARB	0.1W	5%	470 Ω	
R1116	ERJ6GEYJ101	S.M.CARB	0.1W	5%	100 Ω	
R1117	ERJ6GEYJ101	S.M.CARB	0.1W	5%	100 Ω	
R1118	ERJ6GEYJ472	S.M.CARB	0.1W	5%	4K7 Ω	
R1119	ERJ6GEYJ472	S.M.CARB	0.1W	5%	4K7 Ω	
R1120	ERJ6GEYJ101	S.M.CARB	0.1W	5%	100 Ω	
R1121	ERJ6GEYJ101	S.M.CARB	0.1W	5%	100 Ω	
R1123	ERJ6GEYJ101	S.M.CARB	0.1W	5%	100 Ω	
R1125	ERJ6GEYJ472	S.M.CARB	0.1W	5%	4K7 Ω	
R1126	ERJ6GEYJ101	S.M.CARB	0.1W	5%	100 Ω	
R1127	ERJ6GEYJ101	S.M.CARB	0.1W	5%	100 Ω	
R1128	ERJ6GEYJ682	S.M.CARB	0.1W	5%	6K8 Ω	
R1129	ERJ6GEYJ682	S.M.CARB	0.1W	5%	6K8 Ω	
R1130	ERJ6GEYJ103	S.M.CARB	0.1W	5%	10K Ω	
R1131	ERJ6GEYJ103	S.M.CARB	0.1W	5%	10K Ω	
R1132	ERJ6GEYJ101	S.M.CARB	0.1W	5%	100 Ω	
R1133	ERJ6GEYJ273	S.M.CARB	0.1W	5%	27K Ω	
R1136	ERJ6GEYJ823	S.M.CARB	0.1W	5%	82K Ω	
R1137	ERJ6GEY0R00	S.M.CARB	0.1W	5%	0 Ω	
R1138	ERJ6GEYJ474	S.M.CARB	0.1W	5%	470K Ω	
R1139	ERJ6GEYJ471	S.M.CARB	0.1W	5%	470 Ω	
R1140	ERJ6GEYJ471	S.M.CARB	0.1W	5%	470 Ω	
R1141	ERJ6GEYJ471	S.M.CARB	0.1W	5%	470 Ω	
R1145	ERJ6GEYJ101	S.M.CARB	0.1W	5%	100 Ω	
R1146	ERJ6GEYJ101	S.M.CARB	0.1W	5%	100 Ω	
R1147	ERJ6GEYJ101	S.M.CARB	0.1W	5%	100 Ω	
R1148	ERJ6GEYJ101	S.M.CARB	0.1W	5%	100 Ω	
R1149	ERJ6GEYJ223	S.M.CARB	0.1W	5%	22K Ω	

Cct Ref	Parts Number	Description				
R1151	ERJ6GEYJ101	S.M.CARB	0.1W	5%	100 Ω	
R1152	ERJ6GEYJ101	S.M.CARB	0.1W	5%	100 Ω	
R1156	ERJ6GEYJ101	S.M.CARB	0.1W	5%	100 Ω	
R1157	ERJ6GEYJ103	S.M.CARB	0.1W	5%	10K Ω	
R1158	ERJ6GEY0R00	S.M.CARB	0.1W	5%	0 Ω	
R1159	ERJ6GEY0R00	S.M.CARB	0.1W	5%	0 Ω	
R1160	ERJ6GEYJ223	S.M.CARB	0.1W	5%	22K Ω	
R1161	ERJ6GEYJ103	S.M.CARB	0.1W	5%	10K Ω	
R1162	ERJ6GEYJ222	S.M.CARB	0.1W	5%	2K2 Ω	
R1163	ERJ6GEYJ222	S.M.CARB	0.1W	5%	2K2 Ω	
R1164	ERJ6GEYJ332	S.M.CARB	0.1W	5%	3K3 Ω	
R1165	ERJ6GEYJ512	S.M.CARB	0.1W	5%	5K1 Ω	
R1166	ERJ6GEYJ912	S.M.CARB	0.1W	5%	9K1 Ω	
R1167	ERJ6GEYJ100	S.M.CARB	0.1W	5%	10 Ω	
R1168	ERJ6GEYJ473	S.M.CARB	0.1W	5%	47K Ω	
R1169	ERJ6GEYJ472	S.M.CARB	0.1W	5%	4K7 Ω	
R1170	ERJ6GEYJ273	S.M.CARB	0.1W	5%	27K Ω	
R1171	ERJ6GEYJ224	S.M.CARB	0.1W	5%	220K Ω	
R1172	ERJ6GEYJ223	S.M.CARB	0.1W	5%	22K Ω	
R1173	ERJ6GEYJ104	S.M.CARB	0.1W	5%	100K Ω	
R1174	ERJ6GEYJ221	S.M.CARB	0.1W	5%	220 Ω	
R1175	ERJ6GEYJ225	S.M.CARB	0.1W	5%	2M2 Ω	
R1177	ERJ6GEYJ101	S.M.CARB	0.1W	5%	100 Ω	
R1178	ERJ6GEY0R00	S.M.CARB	0.1W	5%	0 Ω	
R2101	ERJ6GEYJ103	S.M.CARB	0.1W	5%	10K Ω	
R2102	ERJ6GEYJ101	S.M.CARB	0.1W	5%	100 Ω	
R2103	ERJ6GEYJ101	S.M.CARB	0.1W	5%	100 Ω	
R2109	ERJ6GEYJ183	S.M.CARB	0.1W	5%	18K Ω	
R2110	ERJ6GEY0R00	S.M.CARB	0.1W	5%	0 Ω	
R2111	ERJ6GEYJ221	S.M.CARB	0.1W	5%	220 Ω	
R2112	ERJ6GEYJ102	S.M.CARB	0.1W	5%	1K Ω	
R2113	ERJ6GEYJ562	S.M.CARB	0.1W	5%	5K6 Ω	
R2114	ERJ6GEYJ101	S.M.CARB	0.1W	5%	100 Ω	
R2115	ERJ6GEYJ222	S.M.CARB	0.1W	5%	2K2 Ω	
R2116	ERJ6GEYJ101	S.M.CARB	0.1W	5%	100 Ω	
R2117	ERJ6GEYJ101	S.M.CARB	0.1W	5%	100 Ω	
R2118	ERJ6GEYJ222	S.M.CARB	0.1W	5%	2K2 Ω	
R2119	ERJ6GEYJ101	S.M.CARB	0.1W	5%	100 Ω	
R2120	ERJ6GEYJ222	S.M.CARB	0.1W	5%	2K2 Ω	
R2302	ERJ6GEYJ104	S.M.CARB	0.1W	5%	100K Ω	
R2303	ERJ6GEYJ101	S.M.CARB	0.1W	5%	100 Ω	
R2304	ERJ6GEYJ471	S.M.CARB	0.1W	5%	470 Ω	
R2305	ERJ6GEYJ102	S.M.CARB	0.1W	5%	1K Ω	
R2306	ERJ6GEYJ103	S.M.CARB	0.1W	5%	10K Ω	
R2308	ERJ6GEYJ104	S.M.CARB	0.1W	5%	100K Ω	
R2309	ERJ6GEYJ101	S.M.CARB	0.1W	5%	100 Ω	
R2310	ERJ6GEYJ471	S.M.CARB	0.1W	5%	470 Ω	
R2311	ERJ6GEYJ102	S.M.CARB	0.1W	5%	1K Ω	
R2312	ERJ6GEYJ103	S.M.CARB	0.1W	5%	10K Ω	
R3001	ERJ6GEYJ101	S.M.CARB	0.1W	5%	100 Ω	
R3002	ERJ6GEYJ471	S.M.CARB	0.1W	5%	470 Ω	
R3003	ERJ6GEYJ101	S.M.CARB	0.1W	5%	100 Ω	
R3004	ERJ6GEYJ153	S.M.CARB	0.1W	5%	15K Ω	
R3005	ERJ6GEYJ101	S.M.CARB	0.1W	5%	100 Ω	
R3006	ERJ6GEYJ471	S.M.CARB	0.1W	5%	470 Ω	
R3007	ERJ6GEYJ101	S.M.CARB	0.1W	5%	100 Ω	
R3008	ERJ6GEYJ153	S.M.CARB	0.1W	5%	15K Ω	
R3009	ERJ6GEYJ750	S.M.CARB	0.1W	5%	75 Ω	
R3010	ERJ6GEYJ750	S.M.CARB	0.1W	5%	75 Ω	
R3011	ERJ6GEYJ750	S.M.CARB	0.1W	5%	75 Ω	
R3012	ERJ6GEYJ750	S.M.CARB	0.1W	5%	75 Ω	
R3013	ERJ6GEYJ101	S.M.CARB	0.1W	5%	100 Ω	
R3014	ERJ6GEYJ471	S.M.CARB	0.1W	5%	470 Ω	
R3015	ERJ6GEYJ101	S.M.CARB	0.1W	5%	100 Ω	
R3016	ERJ6GEYJ153	S.M.CARB	0.1W	5%	15K Ω	
R3017	ERJ6GEYJ101	S.M.CARB	0.1W	5%	100 Ω	

Cct Ref	Parts Number	Description				
R3018	ERJ6GEYJ471	S.M.CARB	0.1W	5%	470 Ω	
R3019	ERJ6GEYJ101	S.M.CARB	0.1W	5%	100 Ω	
R3020	ERJ6GEYJ153	S.M.CARB	0.1W	5%	15K Ω	
R3021	ERJ6GEYJ750	S.M.CARB	0.1W	5%	75 Ω	
R3022	ERJ6GEYJ102	S.M.CARB	0.1W	5%	1K Ω	
R3023	ERJ6GEYJ123	S.M.CARB	0.1W	5%	12K Ω	
R3024	ERJ6GEYJ472	S.M.CARB	0.1W	5%	4K7 Ω	
R3025	ERJ6GEYJ750	S.M.CARB	0.1W	5%	75 Ω	
R3026	ERJ6GEYJ750	S.M.CARB	0.1W	5%	75 Ω	
R3044	ERJ6GEYJ750	S.M.CARB	0.1W	5%	75 Ω	
R3046	ERJ6GEYJ101	S.M.CARB	0.1W	5%	100 Ω	
R3047	ERJ6GEYJ101	S.M.CARB	0.1W	5%	100 Ω	
R3048	ERJ6GEYJ103	S.M.CARB	0.1W	5%	10K Ω	
R3049	ERJ6GEYJ101	S.M.CARB	0.1W	5%	100 Ω	
R3050	ERJ6GEYJ103	S.M.CARB	0.1W	5%	10K Ω	
R3057	ERJ6GEYJ750	S.M.CARB	0.1W	5%	75 Ω	
R3101	ERDS1TJ151	CARBON	0.5W	5%	150 Ω	
R3102	ERDS1TJ151	CARBON	0.5W	5%	150 Ω	
R3103	ERG2FJ221	METAL	2W	5%	220 Ω <sup>△</sup>	
R3104	ERG2FJ221	METAL	2W	5%	220 Ω <sup>△</sup>	
R3105	ERJ6GEYJ101	S.M.CARB	0.1W	5%	100 Ω	
R3106	ERJ6GEYJ101	S.M.CARB	0.1W	5%	100 Ω	
R3107	ERJ6GEYJ153	S.M.CARB	0.1W	5%	15K Ω	
R3108	ERJ6GEYJ153	S.M.CARB	0.1W	5%	15K Ω	
R3402	ERJ6GEYJ750	S.M.CARB	0.1W	5%	75 Ω	
R3403	ERJ6GEYJ101	S.M.CARB	0.1W	5%	100 Ω	
R3404	ERJ6GEYJ242	S.M.CARB	0.1W	5%	2K4 Ω	
R3405	ERJ6GEYJ104	S.M.CARB	0.1W	5%	100K Ω	
R3406	ERJ6GEYJ301	S.M.CARB	0.1W	5%	300 Ω	
R3407	ERJ6GEYJ123	S.M.CARB	0.1W	5%	12K Ω	
R3408	ERJ6GEYJ472	S.M.CARB	0.1W	5%	4K7 Ω	
R3409	ERJ6GEYJ750	S.M.CARB	0.1W	5%	75 Ω	
R3601	ERJ6GEYJ101	S.M.CARB	0.1W	5%	100 Ω	
R3602	ERJ6GEYJ101	S.M.CARB	0.1W	5%	100 Ω	
R3603	ERJ6GEYJ101	S.M.CARB	0.1W	5%	100 Ω	
R3604	ERJ6GEYJ101	S.M.CARB	0.1W	5%	100 Ω	
R3605	ERJ6GEYJ101	S.M.CARB	0.1W	5%	100 Ω	
R3606	ERJ6GEYJ101	S.M.CARB	0.1W	5%	100 Ω	
R3607	ERJ6GEYJ472	S.M.CARB	0.1W	5%	4K7 Ω	
R3608	ERJ6GEYJ752	S.M.CARB	0.1W	5%	7K5 Ω	
R3609	ERJ6GEY0R00	S.M.CARB	0.1W	5%	0 Ω	
R3610	ERJ6GEYJ102	S.M.CARB	0.1W	5%	1K Ω	
<b>CAPACITORS</b>						
C102	ECUV1H103ZFX	S.M. CAP	50V		10nF	
C103	ECJ2VF1H104Z	ELECT	350V		100nF	
C106	ECUV1H560JCX	S.M. CAP	50V		56pF	
C107	ECJ2VF1H104Z	ELECT	350V		100nF	
C108	ECA1CM100GB	ELECT	16V		10μF	
C109	ECUV1H102JCX	S.M. CAP	50V		1nF	
C110	ECUV1H103ZFX	S.M. CAP	50V		10nF	
C111	ECA1HMR33GB	ELECT	50V		10nF	
C117	ECUV1H103ZFX	S.M. CAP	50V		10nF	
C118	ECJ2VF1H104Z	ELECT	350V		100nF	
C119	ECA1CM221GB	ELECT	16V		220μF	
C120	ECA1CM221GB	ELECT	16V		220μF	
C121	ECUV1H561KBX	S.M. CAP	50V		560pF	
C124	ECUV1H220JCX	S.M. CAP	50V		22pF	
C125	ECUV1H100DCX	S.M. CAP	50V		10pF	
C252	ECUV1H223KBX	S.M. CAP	50V		22nF	
C253	ECA1HM4R7GB	ELECT	50V		4.7μF	
C255	ECA1EM101GB	ELECT	25V		100μF	
C256	ECUV1H223KBX	S.M. CAP	50V		22nF	
C257	ECA1HM4R7GB	ELECT	50V		4.7μF	
C260	ECA1VM102GB	ELECT	35V		1nF	
C261	ECA1VM102GB	ELECT	35V		1nF	
C263	ECA1HM010GB	ELECT	50V		1μF	

Cct Ref	Parts Number	Description			
C264	ECA1HHG222E	ELECT	50V	1μF	
C266	ECA1HM010GB	ELECT	50V	1μF	
C267	ECJ2VB1H104K	ELECT	350V	100nF	
C268	ECJ2VB1H104K	ELECT	350V	100nF	
C270	ECJ2VB1H104K	ELECT	350V	100nF	
C301	ECJ2VB1C104K	ELECT	350V	100nF	
C302	ECJ2VB1C104K	ELECT	350V	100nF	
C303	ECJ2VB1C104K	ELECT	350V	100nF	
C304	ECA1CM100GB	ELECT	16V	10μF	
C354	ECQM2104KZ	FILM	250V	100nF	
C355	ECUV1H471JCX	S.M. CAP	50V	470pF	
C356	ECUV1H471JCX	S.M. CAP	50V	470pF	
C357	ECUV1H471JCX	S.M. CAP	50V	470pF	
C358	ECQM1H224J	FILM	50V	220nF	
C360	ECKC3D152J	CERAMIC	2KV	1.5nF	△
C361	ECA1HMR47GB	ELECT	50V	1.5nF	
C363	ECA1VM471GB	ELECT	35V	470μF	
C364	ECJ2VF1H103Z	ELECT	350V	10nF	
C451	ECUV1H102JX	S.M. CAP	50V	1nF	
C453	ECUV1H152KBM	S.M. CAP	50V	1.5pF	
C454	ECUV1H223KBM	S.M. CAP	50V	22nF	
C455	ECA1HM100GB	ELECT	50V	10μF	
C456	ECA1HHG221B	ELECT	50V	220μF	
C458	ECQB1222JF3	FILM	100V	2.2nF	
C459	222236516154	FILM	160V	150nF	
C461	ECCR2H270J	CERAMIC	500V	27pF	
C508	ECQV1H105JZ	FILM	50V	1μF	
C509	ECA1VM470B	ELECT	35V	47μF	
C510	ECUV1H104KBX	S.M. CAP	50V	100nF	
C511	ECQM2683JZ	FILM	250V	68nF	
C552	ECWH15H102JN	FILM	1500V	1nF	
C557	ECKC2H471J	CERAMIC	500V	470pF	△
C558	ECA1HHG471E	ELECT	50V	470μF	
C560	ECA2GHG2R2B	ELECT	400V	470μF	
C561	ECA1EHG102B	ELECT	25V	470μF	
C562	ECKC2H101J	CERAMIC	500V	100pF	△
C563	ECA2EHG220B	ELECT	250V	20μF	
C564	ECEA2AU2R2	ELECT	100V	2.2μF	
C565	ECQP1H273J	FILM	100V	2.2μF	
C566	ECKC2H471J	CERAMIC	500V	470pF	△
C567	ECA1EHG102B	ELECT	25V	470pF	
C568	ECKC2H471J	CERAMIC	500V	470pF	△
C569	ECKC2H102J	CERAMIC	500V	1nF	△
C601	ECUV1H104KBX	S.M. CAP	50V	100nF	
C602	ECA1HM101GB	ELECT	50V	100μF	
C603	ECUV1H102JCX	S.M. CAP	50V	1nF	
C604	ECJ2VF1H223Z	ELECT	350V	22nF	
C605	ECA1HM101GB	ELECT	50V	100μF	
C606	ECA1HM3R3GB	ELECT	50V	3.3μF	
C607	ECJ2VF1H104Z	ELECT	350V	100nF	
C608	ECUV1H153KBX	S.M. CAP	50V	15nF	
C609	ECUV1H153KBX	S.M. CAP	50V	15nF	
C610	ECUV1H153KBX	S.M. CAP	50V	15nF	
C611	ECUV1H153KBX	S.M. CAP	50V	15nF	
C612	ECUV1H153KBX	S.M. CAP	50V	15nF	
C613	ECUV1H153KBX	S.M. CAP	50V	15nF	
C614	ECUV1H050CCX	S.M. CAP	50V	50pF	
C615	ECUV1H050CCX	S.M. CAP	50V	50pF	
C616	ECA1HM101GB	ELECT	50V	100μF	
C617	ECUV1H223KBM	S.M. CAP	50V	22nF	
C618	ECA1CM221GB	ELECT	16V	220μF	
C619	ECJ2VB1H473K	ELECT	350V	47nF	
C620	ECA1HM101GB	ELECT	50V	100μF	
C621	ECJ2VB1C104K	ELECT	350V	100nF	
C622	ECUV1H683KBX	S.M. CAP	50V	68nF	
C623	ECUV1H102JCX	S.M. CAP	50V	1nF	

Cct Ref	Parts Number	Description			
C624	ECJ3VB1C474K	ELECT	3.5KV	470nF	
C625	ECJ3VB1C474K	ELECT	3.5KV	470nF	
C626	ECJ3VB1C474K	ELECT	3.5KV	470nF	
C627	ECJ3VB1C474K	ELECT	3.5KV	470nF	
C628	ECA1CM100GB	ELECT	16V	10μF	
C629	ECUV1H104KBX	S.M. CAP	50V	100nF	
C630	ECUV1H100DCX	S.M. CAP	50V	10pF	
C631	ECUV1H683ZFX	S.M. CAP	50V	68nF	
C632	ECUV1H270JCX	S.M. CAP	50V	27pF	
C633	ECUV1H271JCX	S.M. CAP	50V	270pF	
C634	ECUV1H271JCX	S.M. CAP	50V	270pF	
C635	ECUV1H180JCX	S.M. CAP	50V	18pF	
C636	ECUV1H271JCX	S.M. CAP	50V	270pF	
C637	ECUV1H101JCX	S.M. CAP	50V	100pF	
C638	ECUV1H471JCX	S.M. CAP	50V	470pF	
C639	ECUV1H332KBM	S.M. CAP	50V	3.3nF	
C701	ECA1HHG101B	ELECT	50V	100μF	
C702	ECUV1H103KBX	S.M. CAP	50V	10nF	
C703	ECEA1HGE100	ELECT	50V	10μF	
C704	ECQB1H223K	FILM	50V	22nF	
C804	222233510224	FILM	50V	220nF	
C806	ECKWNA101MBC	CERAMIC	400V	100μF	
C807	ECKC2H472J	CERAMIC	500V	4.7nF	△
C808	ECKC2H472J	CERAMIC	500V	4.7nF	△
C809	ECKC2H472J	CERAMIC	500V	4.7nF	△
C810	ECKC2H472J	CERAMIC	500V	4.7nF	△
C814	ECKC3D102J	CERAMIC	2KV	1nF	△
C815	ECKC1H471J	CERAMIC	50V	470pF	
C816	ECA1EM101GB	ELECT	25V	100μF	
C817	ECQE6104K	FILM	600V	100nF	△
C818	ECKWNA332MEC	CERAMIC	250V	3.3nF	
C819	ECQB1H152K	FILM	50V	1.5nF	
C850	ECKC3D471JB	CERAMIC	2KV	470pF	△
C851	ECA2CM221E	ELECT	160V	220μF	
C852	ECA2CHG101E	ELECT	160V	100μF	
C853	ECKC2H471J	CERAMIC	500V	470pF	△
C854	ECA1EM102GB	ELECT	25V	100μF	
C855	ECKC2H471J	CERAMIC	500V	470pF	△
C856	ECA1AHG222B	ELECT	10V	470pF	
C857	ECKC2H471J	CERAMIC	500V	470pF	△
C858	ECEA1HGE102	ELECT	50V	470pF	
C859	ECJ2VF1H104Z	ELECT	350V	100nF	
C860	ECA1HM101GB	ELECT	50V	100μF	
C862	ECJ2VF1H104Z	ELECT	350V	100nF	
C863	ECA1HM101GB	ELECT	50V	100μF	
C866	ECJ2VF1H104Z	ELECT	350V	100nF	
C867	ECA1CM100GB	ELECT	16V	10μF	
C868	ECA1CM100GB	ELECT	16V	10μF	
C869	ECA1EM101GB	ELECT	25V	100μF	
C870	ECA1EM471GB	ELECT	25V	470μF	
C871	ECA1CM102B	ELECT	16V	470μF	
C872	ECA1CM471GB	ELECT	16V	470μF	
C873	ECA1CM100GB	ELECT	16V	10μF	
C875	ECA2CM4R7B	ELECT	160V	10μF	
C876	ECA1AHG471E	ELECT	10V	470pF	
C1051	ECUV1H103KBX	S.M. CAP	50V	10nF	
C1052	ECA1HM101GB	ELECT	50V	100μF	
C1053	ECUV1H331JCX	S.M. CAP	50V	330pF	
C1101	ECJ2VF1H104Z	ELECT	350V	100nF	
C1102	ECA0JM101G	ELECT	6.3V	100μF	
C1103	ECUV1H220JCX	S.M. CAP	50V	22pF	
C1104	ECUV1H220JCX	S.M. CAP	50V	22pF	
C1105	ECUV1H101JCX	S.M. CAP	50V	100pF	
C1108	ECJ2VB1H333K	ELECT	350V	33nF	
C1111	ECA1CM100GB	ELECT	16V	10μF	
C1112	ECUV1H103KBX	S.M. CAP	50V	10nF	

Cct Ref	Parts Number	Description		
C1115	ECJ3VB1C474K	ELECT	3.5KV	470nF
C1116	ECUV1H472KBX	S.M. CAP	50V	4.7nF
C1117	ECJ2VF1H104Z	ELECT	350V	100nF
C1118	ECUV1H103KBX	S.M. CAP	50V	10nF
C1119	ECUV1H221JCX	S.M. CAP	50V	220pF
C1120	ECJ2VF1H104Z	ELECT	350V	100nF
C1121	ECUV1H221JCX	S.M. CAP	50V	220pF
C1123	ECUV1H101JCX	S.M. CAP	50V	100pF
C1124	ECUV1H391JCX	S.M. CAP	50V	390pF
C1125	ECUV1H391JCX	S.M. CAP	50V	390pF
C1126	ECUV1H391JCX	S.M. CAP	50V	390pF
C1127	ECUV1H221JCX	S.M. CAP	50V	220pF
C1128	ECUV1H223KBX	S.M. CAP	50V	22nF
C1129	ECUV1H270JCX	S.M. CAP	50V	27pF
C2101	ECUV1H102JCX	S.M. CAP	50V	1nF
C2102	ECUV1H102JCX	S.M. CAP	50V	1nF
C2103	ECUV1H102JCX	S.M. CAP	50V	1nF
C2104	ECUV1H102JCX	S.M. CAP	50V	1nF
C2105	ECUV1H102JCX	S.M. CAP	50V	1nF
C2106	ECUV1H102JCX	S.M. CAP	50V	1nF
C2107	ECUV1H102JCX	S.M. CAP	50V	1nF
C2108	ECUV1H102JCX	S.M. CAP	50V	1nF
C2109	ECUV1H102JCX	S.M. CAP	50V	1nF
C2110	ECUV1H102JCX	S.M. CAP	50V	1nF
C2111	ECA1CM100GB	ELECT	16V	10µF
C2112	ECA1CM100GB	ELECT	16V	10µF
C2113	ECA1HM3R3GB	ELECT	50V	3.3µF
C2114	ECJ2VF1H104Z	ELECT	350V	100nF
C2115	ECUV1H221JCX	S.M. CAP	50V	220pF
C2116	ECUV1H221JCX	S.M. CAP	50V	220pF
C2117	ECUV1H221JCX	S.M. CAP	50V	220pF
C2118	ECUV1H221JCX	S.M. CAP	50V	220pF
C2119	ECUV1H221JCX	S.M. CAP	50V	220pF
C2120	ECUV1H221JCX	S.M. CAP	50V	220pF
C2121	ECA1CM100GB	ELECT	16V	10µF
C2122	ECJ2VF1H104Z	ELECT	350V	100nF
C2123	ECUV1H221JCX	S.M. CAP	50V	220pF
C2124	ECUV1H070DTX	S.M. CAP	50V	70pF
C2125	ECUV1H470JCX	S.M. CAP	50V	47pF
C2126	ECUV1H070DTX	S.M. CAP	50V	70pF
C2127	ECUV1H010CCX	S.M. CAP	50V	1pF
C2128	ECUV1H010CCX	S.M. CAP	50V	1pF
C2129	ECA1CM102B	ELECT	16V	1pF
C2130	ECA1CM331B	ELECT	16V	330µF
C2131	ECUV1H103ZFX	S.M. CAP	50V	10nF
C2132	ECUV1H103ZFX	S.M. CAP	50V	10nF
C2133	ECUV1H103ZFX	S.M. CAP	50V	10nF
C2134	ECUV1H103ZFX	S.M. CAP	50V	10nF
C2135	ECA1HM101GB	ELECT	50V	100µF
C2136	ECJ2VF1H104Z	ELECT	350V	100nF
C2137	ECA1CM100GB	ELECT	16V	10µF
C2138	ECUV1H471KBX	S.M. CAP	50V	470pF
C2139	ECUV1H221JCX	S.M. CAP	50V	220pF
C2140	ECA1HM101GB	ELECT	50V	100µF
C2141	ECUV1H152JCX	S.M. CAP	50V	1.5pF
C2301	ECUV1H222JCX	S.M. CAP	50V	2.2nF
C2302	ECA1CM470GB	ELECT	16V	47µF
C2303	ECUV1H222JCX	S.M. CAP	50V	2.2nF
C2304	ECA1CM470GB	ELECT	16V	47µF
C3001	ECUV1H222JCX	S.M. CAP	50V	2.2nF
C3002	ECUV1H222JCX	S.M. CAP	50V	2.2nF
C3003	ECA1CM470GB	ELECT	16V	47µF
C3005	ECUV1H561JCX	S.M. CAP	50V	560pF
C3006	ECJ3VB1C474K	ELECT	3.5KV	470nF
C3007	ECUV1H222JCX	S.M. CAP	50V	2.2nF
C3008	ECUV1H222JCX	S.M. CAP	50V	2.2nF
C3009	ECUV1H222JCX	S.M. CAP	50V	2.2nF

Cct Ref	Parts Number	Description		
C3010	ECA1CM470GB	ELECT	16V	47µF
C3012	ECUV1H561JCX	S.M. CAP	50V	560pF
C3013	ECJ3VB1C474K	ELECT	3.5KV	470nF
C3014	ECUV1H222JCX	S.M. CAP	50V	2.2nF
C3015	ECUV1H222JCX	S.M. CAP	50V	2.2nF
C3016	ECUV1H222JCX	S.M. CAP	50V	2.2nF
C3017	ECA1CM470GB	ELECT	16V	47µF
C3019	ECUV1H561JCX	S.M. CAP	50V	560pF
C3020	ECJ3VB1C474K	ELECT	3.5KV	470nF
C3021	ECUV1H222JCX	S.M. CAP	50V	2.2nF
C3022	ECUV1H222JCX	S.M. CAP	50V	2.2nF
C3023	ECUV1H222JCX	S.M. CAP	50V	2.2nF
C3024	ECA1CM470GB	ELECT	16V	47µF
C3026	ECUV1H561JCX	S.M. CAP	50V	560pF
C3027	ECJ3VB1C474K	ELECT	3.5KV	470nF
C3028	ECUV1H222JCX	S.M. CAP	50V	2.2nF
C3029	ECA1HM101GB	ELECT	50V	100µF
C3032	ECUV1H271JCX	S.M. CAP	50V	270pF
C3033	ECUV1H271JCX	S.M. CAP	50V	270pF
C3034	ECUV1H271JCX	S.M. CAP	50V	270pF
C3035	ECUV1H271JCX	S.M. CAP	50V	270pF
C3101	ECUV1H104KBX	S.M. CAP	50V	100nF
C3102	ECUV1E104KBX	S.M. CAP	25V	100nF
C3103	ECUV1H561JCX	S.M. CAP	50V	560pF
C3104	ECUV1H561JCX	S.M. CAP	50V	560pF
C3105	ECUV1H561JCX	S.M. CAP	50V	560pF
C3106	ECUV1H561JCX	S.M. CAP	50V	560pF
C3107	ECA1HM470GB	ELECT	50V	47µF
C3108	ECA1HM470GB	ELECT	50V	47µF
C3111	ECUV1H391JCX	S.M. CAP	50V	390pF
C3112	ECUV1H271JCX	S.M. CAP	50V	270pF
C3401	ECQM1H224J	FILM	50V	220nF
C3402	ECUV1H101JCX	S.M. CAP	50V	100pF
C3403	ECA1HM101GB	ELECT	50V	100µF
C3404	ECQM1H224J	FILM	50V	220nF
C3405	ECUV1H180JCX	S.M. CAP	50V	18pF
C3406	ECUV1H271JCX	S.M. CAP	50V	270pF
C3407	ECUV1H271JCX	S.M. CAP	50V	270pF
C3408	ECA1HM101GB	ELECT	50V	100µF
C3601	ECA1HM101GB	ELECT	50V	100µF
JSE28	ECUV1H104KBX	S.M. CAP	50V	100nF
<b>TERMINALS AND LINKS</b>				
JK2301	JPJ841101320	RCA / HEADPHONE JACK		
JK3001	0350808500	SCART SOCKET		
JK3101	TJB16673	A.V. TERMINAL		
<b>SWITCHES</b>				
S801	ESB92S11B	SWITCH		△
S1201	EVQ21405R	SWITCH		
S1202	EVQ21405R	SWITCH		
S1203	EVQ21405R	SWITCH		
S1204	EVQ21405R	SWITCH		
S1205	EVQ21405R	SWITCH		
<b>DIFFERENCES FOR MODEL TX-21MK1/M</b>				
<b>MECHANICAL PARTS</b>				
11	ZTUZAE450A	ANODE LEAD		△
12	TKU8E00370	BACK COVER		△
13	A51EER35X70	C.R.T.		△
14	TKY8E400-1	CABINET		△
15	VP15005-35	CRT FIXING SCREW		
16	TLK8E05143	DEGAUSS COIL		△
17	TNP8EE009CG	E P.C.B.		△
18	ZTFL94001A	F.B.T.		△
19	TQF8E2781	MODEL LABEL		△

Cct Ref	Parts Number	Description			
20	TBM8E1928	PANASONIC BADGE			
21	TNP8EY013AC	Y P.C.B.			△
<b>MISCELLANEOUS COMPONENTS</b>					
	TPC8E4669	OUTER CARTON			
	TPD8E606-1	TOP CUSHION			
	TPD8E607-1	BOTTOM CUSHION			
<b>I.C.s</b>					
IC850	SE130N	ERROR AMPLIFIER			
IC1103	XDG2-01AA	EAROM *			
<b>DIODES</b>					
D702	MTZJT776.2B	DIODE			
D705	MTZJT-775.1A	DIODE			
<b>TRANSISTORS</b>					
Q351	2SA1767	TRANSISTOR			
Q352	2SA1767	TRANSISTOR			
Q353	2SA1767	TRANSISTOR			
Q551	BU4508AXLB	TRANSISTOR			
<b>TRANSFORMERS</b>					
T801	ETS39AG1K7AD	TRANSFORMER			△
<b>COILS</b>					
L552	ELH5L4104	COIL			
L554	ELC18B332L	COIL			
<b>FILTERS</b>					
L804	ELF19N008A	LINE FILTER			
<b>RESISTORS</b>					
	ERQ2ABJP2R7S	FUSIBLE	2W	5%	2R7 Ω
R252	ERJ6GEYJ272	S.M.CARB	0.1W	5%	2K7 Ω
R257	ERJ6GEYJ330	S.M.CARB	0.1W	5%	33 Ω
R258	ERJ6GEYJ272	S.M.CARB	0.1W	5%	2K7 Ω
R259	ERJ6GEYJ330	S.M.CARB	0.1W	5%	33 Ω
R357	ERDS1TJ104	CARBON	0.5W	5%	100K Ω
R358	ERDS1TJ104	CARBON	0.5W	5%	100K Ω
R359	ERDS1TJ104	CARBON	0.5W	5%	100K Ω
R363	ERDS1TJ103	CARBON	0.5W	5%	10K Ω
R364	ERDS1TJ103	CARBON	0.5W	5%	10K Ω
R365	ERDS1TJ103	CARBON	0.5W	5%	10K Ω
R369	ERD25TJ123	CARBON	0.25W	5%	12K Ω
R370	ERD25TJ272	CARBON	0.25W	5%	2K7 Ω
R461	ERW2PK1R8	WOUND	2W	5%	1R8 Ω △
R507	ERG1SJ331	METAL	1W	5%	330 Ω
R563	ERJ6GEYJ684	S.M.CARB	0.1W	5%	680K Ω
R564	ERJ6GEYJ753	S.M.CARB	0.1W	5%	75K Ω
R706	ERJ6GEYJ512	S.M.CARB	0.1W	5%	5K1 Ω
R707	ERJ6GEYJ102	S.M.CARB	0.1W	5%	1K Ω
R712	ERJ6GEYJ561	S.M.CARB	0.1W	5%	560 Ω
R810	ERW2PKR33	WOUND	2W	20%	R33 Ω △
R2104	ERJ6GEYJ101	S.M.CARB	0.1W	5%	100 Ω
R2105	ERJ6GEYJ101	S.M.CARB	0.1W	5%	100 Ω
R2106	ERJ6GEYJ101	S.M.CARB	0.1W	5%	100 Ω
R2107	ERJ6GEYJ101	S.M.CARB	0.1W	5%	100 Ω
R2108	ERJ6GEYJ101	S.M.CARB	0.1W	5%	100 Ω
<b>CAPACITORS</b>					
C251	ECA1EM470GB	ELECT	25V		47μF
C254	ECQM1H334J	FILM	50V		330nF
C258	ECA1EM470GB	ELECT	25V		47μF
C259	ECQM1H334J	FILM	50V		330nF
C262	ECQM1H684J	FILM	50V		680nF
C265	ECQM1H684J	FILM	50V		680nF
C351	ECUV1H090DCN	S.M. CAP	50V		90pF
C352	ECUV1H090DCN	S.M. CAP	50V		90pF
C353	ECUV1H090DCN	S.M. CAP	50V		90pF
C365	ECA1CM100GB	ELECT	16V		10μF
C551	ECKC3D271JB	CERAMIC	2KV		10μF △

Cct Ref	Parts Number	Description			
C554	ECWF2824JBB	FILM	200V		820nF △
C555	ECWH15H822JN	FILM	1500V		8.2nF
C556	ECQF4273JZH	FILM	400V		27nF △
C559	ECWF2824JBB	FILM	200V		820nF △
C705	ECQB1H152K	FILM	50V		1.5nF
C811	43504A9157M0	ELECT	400V		150μF
<b>DIFFERENCES FOR MODEL TX-28MK1/M</b>					
<b>MECHANICAL PARTS</b>					
11	ZTUZAE550A	ANODE LEAD			△
12	TKU8E00350	BACK COVER			△
13	A66ECF50X42	C.R.T.			△
14	TKY8E194-1	CABINET			△
15	VP17005-32	CRT FIXING SCREW			
16	TLK8E05140	DEGAUSS COIL			△
17	TNP8EE009CS	E P.C.B.			△
18	ZTFL94002A	F.B.T.			△
19	TQF8E2861	MODEL LABEL			△
20	TBM8E1929	PANASONIC BADGE			
21	TNP8EY012AC	Y P.C.B.			△
<b>MISCELLANEOUS COMPONENTS</b>					
	TPC8E4671	OUTER CARTON			
	TPD8E719	TOP CUSHION			
	TPD8E720	BOTTOM CUSHION			
<b>I.C.s</b>					
IC850	SE140N	ERROR AMPLIFIER			
IC1103	XDG2-01CA	EAROM *			
<b>DIODES</b>					
D702	MTZJT-775.1C	DIODE			
D704	MA29TA5	DIODE			
D705	MTZJT-775.6C	DIODE			
D851	MTZJT776.2B	DIODE			
D852	MA165TA5	DIODE			
D901	MA165TA5	DIODE			
D902	MA165TA5	DIODE			
D904	MA165TA5	DIODE			
D905	MA165TA5	DIODE			
D906	RLS72TE-11	DIODE			
<b>TRANSISTORS</b>					
	2SA1767	TRANSISTOR			
Q351	TYMQ0002	TRANSISTOR			
Q352	TYMQ0002	TRANSISTOR			
Q353	TYMQ0002	TRANSISTOR			
Q551	2SD1577LB	TRANSISTOR			
Q905	BC847B	TRANSISTOR			
Q906	BC847B	TRANSISTOR			
Q907	BC857B	TRANSISTOR			
Q908	2SA1535AQLB	TRANSISTOR			
Q909	2SC3944AQLB	TRANSISTOR			
Q950	BC847B	TRANSISTOR			
Q951	FMY4T148	TRANSISTOR			
<b>TRANSFORMERS</b>					
T801	TLP8E1006	TRANSFORMER			△
<b>COILS</b>					
L552	ELH5L4105	COIL			
L554	ELC18B102L	COIL			
L901	EXCELSA24T	COIL			
L902	EXCELSA24T	COIL			
<b>FILTERS</b>					
L804	ELF18N010A	LINE FILTER			
<b>RESISTORS</b>					
JA1	ERJ6GEY0R00	S.M.CARB	0.1W	5%	0 Ω

Cct Ref	Parts Number	Description			
JA2	ERJ6GEY0R00	S.M.CARB	0.1W	5%	0 Ω
JA3	ERJ6GEY0R00	S.M.CARB	0.1W	5%	0 Ω
R252	ERJ6GEYJ242	S.M.CARB	0.1W	5%	2K4 Ω
R257	ERJ6GEYJ270	S.M.CARB	0.1W	5%	27 Ω
R258	ERJ6GEYJ242	S.M.CARB	0.1W	5%	2K4 Ω
R259	ERJ6GEYJ270	S.M.CARB	0.1W	5%	27 Ω
R357	ERDS1TJ114	CARBON	0.5W	5%	110K Ω
R358	ERDS1TJ114	CARBON	0.5W	5%	110K Ω
R359	ERDS1TJ114	CARBON	0.5W	5%	110K Ω
R363	ERD25TJ103	CARBON	0.25W	5%	10K Ω
R364	ERD25TJ103	CARBON	0.25W	5%	10K Ω
R365	ERD25TJ103	CARBON	0.25W	5%	10K Ω
R369	ERD25TJ472	CARBON	0.25W	5%	4K7 Ω
R370	ERJ6GEYJ102	S.M.CARB	0.1W	5%	1K Ω
R377	ERQ1ABJP5R1	METAL	0.5W	5%	5R1 Ω <sup>△</sup>
R461	ERW2PK1R2	WOUND	2W	10%	1R2 Ω <sup>△</sup>
R507	ERG1FJ101P	METAL	1W	5%	100 Ω <sup>△</sup>
R563	ERJ6GEYJ474	S.M.CARB	0.1W	5%	470K Ω
R564	ERJ6GEYJ623	S.M.CARB	0.1W	5%	62K Ω
R706	ERJ6GEYJ103	S.M.CARB	0.1W	5%	10K Ω
R707	ERJ6GEYJ391	S.M.CARB	0.1W	5%	390 Ω
R712	ERJ6GEYJ102	S.M.CARB	0.1W	5%	1K Ω
R810	ERW2PKR27	WOUND	2W	10%	R27 Ω <sup>△</sup>
R913	ERJ6GEYJ473	S.M.CARB	0.1W	5%	47K Ω
R914	ERJ6GEYJ822	S.M.CARB	0.1W	5%	8K2 Ω
R915	ERJ6GEYJ152	S.M.CARB	0.1W	5%	1K5 Ω
R916	ERJ6GEYJ391	S.M.CARB	0.1W	5%	390 Ω
R919	ERQ14AJW390	FUSIBLE	0.25W	5%	39 Ω <sup>△</sup>
R920	ERQ14AJW390	FUSIBLE	0.25W	5%	39 Ω <sup>△</sup>
R921	ERD25TJ471	CARBON	0.25W	5%	470 Ω
R922	ERD25TJ393	CARBON	0.25W	5%	39K Ω
R923	ERD25TJ393	CARBON	0.25W	5%	39K Ω
R924	ERDS1FJ390	CARBON	0.5W	5%	39 Ω <sup>△</sup>
R925	ERJ6GEY0R00	S.M.CARB	0.1W	5%	0 Ω
R926	ERJ6GEY0R00	S.M.CARB	0.1W	5%	0 Ω
R927	ERD25TJ471	CARBON	0.25W	5%	470 Ω
R928	ERD25TJ5R6	CARBON	0.25W	5%	5R6 Ω
R929	ERDS1FJ471	CARBON	0.5W	5%	470 Ω <sup>△</sup>
R930	ERD25TJ5R6	CARBON	0.25W	5%	5R6 Ω
R931	ERDS1FJ390	CARBON	0.5W	5%	39 Ω <sup>△</sup>
R935	ERQ14AJW3R9	FUSIBLE	0.25W	5%	3R9 Ω <sup>△</sup>
R936	ERQ1CJP331	FUSIBLE	1W	5%	330 Ω <sup>△</sup>
R951	ERJ6GEYJ391	S.M.CARB	0.1W	5%	390 Ω
R952	ERJ6GEYJ102	S.M.CARB	0.1W	5%	1K Ω
R953	ERJ6GEYJ750	S.M.CARB	0.1W	5%	75 Ω
R954	ERJ6GEYJ391	S.M.CARB	0.1W	5%	390 Ω
<b>CAPACITORS</b>					
C251	ECA1EM100GB	ELECT	25V		0.1μF
C254	ECQM1H274J	FILM	50V		270nF
C258	ECA1EM100GB	ELECT	25V		0.1μF
C259	ECQM1H274J	FILM	50V		270nF
C262	ECQM1H474J	FILM	50V		470nF
C265	ECQM1H474J	FILM	50V		470nF
C351	ECUV1H090DCX	S.M. CAP	50V		470nF
C352	ECUV1H090DCX	S.M. CAP	50V		470nF
C353	ECUV1H090DCX	S.M. CAP	50V		470nF
C366	ECA1CM100GB	ELECT	16V		10μF
C551	ECKC3D152J	CERAMIC	2KV		1.5nF <sup>△</sup>
C554	ECWF2H514J	FILM	500V		510nF <sup>△</sup>
C555	ECWH15H103JN	FILM	1500V		10nF
C556	ECQM4333JC	FILM	400V		33nF
C559	ECWF2H684J	FILM	500V		680nF <sup>△</sup>
C705	ECQB1H222J	FILM	50V		2.2nF
C811	43504A9187M0	ELECT	400V		180μF
C902	ECA1VM101GB	ELECT	35V		100μF
C903	ECJ2VB1H472K	ELECT	350V		4.7nF

Cct Ref	Parts Number	Description			
C904	ECJ2VB1H472K	ELECT	350V		4.7nF
C906	ECUV1H471KBX	S.M. CAP	50V		470pF
C908	ECUV1H151JCX	S.M. CAP	50V		150pF
C909	ECKC2H472J	CERAMIC	500V		4.7nF <sup>△</sup>
C910	ECKC2H472J	CERAMIC	500V		4.7nF <sup>△</sup>
C911	ECUV1H151JCX	S.M. CAP	50V		150pF
C912	ECEA2CU100	ELECT	160V		10μF
C913	ECA1HM101GB	ELECT	50V		100μF
C914	ECA1HM101GB	ELECT	50V		100μF
C916	ECEA2CGE100	ELECT	160V		10μF
C950	ECJ2VB1C104K	ELECT	350V		100nF

# SCHEMATIC DIAGRAMS FOR MODELS

## TX-28MK1/M / TX-21MK1/M

### (EURO-4 CHASSIS)

#### IMPORTANT SAFETY NOTICE

Components identified by  mark have special characteristics important for safety. When replacing any of these components, use only manufacturers' specified parts.

#### NOTE

1. RESISTOR

All resistors are carbon ¼W resistor, unless marked otherwise.  
Unit of resistance is OHM ( $\Omega$ ) (k=1,000, M=1,000,000)

2. CAPACITORS

All capacitors are ceramic 50V unless marked otherwise.  
Unit of capacitance is  $\mu$ F unless otherwise stated.

3. COIL

Unit of inductance is  $\mu$ H, unless otherwise stated.

4. TEST POINT

 Test Point Position

5. EARTH SYMBOL

 Chassis Earth (Cold)

 Line Earth (Hot)

6. VOLTAGE MEASUREMENT

Voltage is measured by a d.c. voltmeter.  
Measurement conditions are as follows:  
Power source                    a.c. 220V-240V, 50Hz  
Receiving Signal                Colour Bar signal (RF)  
All customer controls            Maximum position

7.

 Indicates the Video signal path

 Indicates the Audio signal path

These schematic diagrams are the latest at time of printing and are subject to change without notice.

#### REMARKS

- Do not touch the hot part, or the hot and cold parts at the same time, as you are liable to a shock hazard.
- Do not short circuit the hot and cold circuits as electrical components may be damaged.
- Do not connect an instrument, such as an oscilloscope, to the hot and cold circuits simultaneously as this may cause fuse failure. Connect the earth of the instruments to the earth connection of the circuit being measured.
- Make sure to disconnect the power plug before removing the chassis.

#### NOTE

- The Power Supply Circuit contains a circuit area, which uses a separate power supply to isolate the earth connection. The circuit is defined by HOT and COLD indications in the schematic diagram. All circuits, except the Power Circuit, are COLD.

# TX-28MK1/M

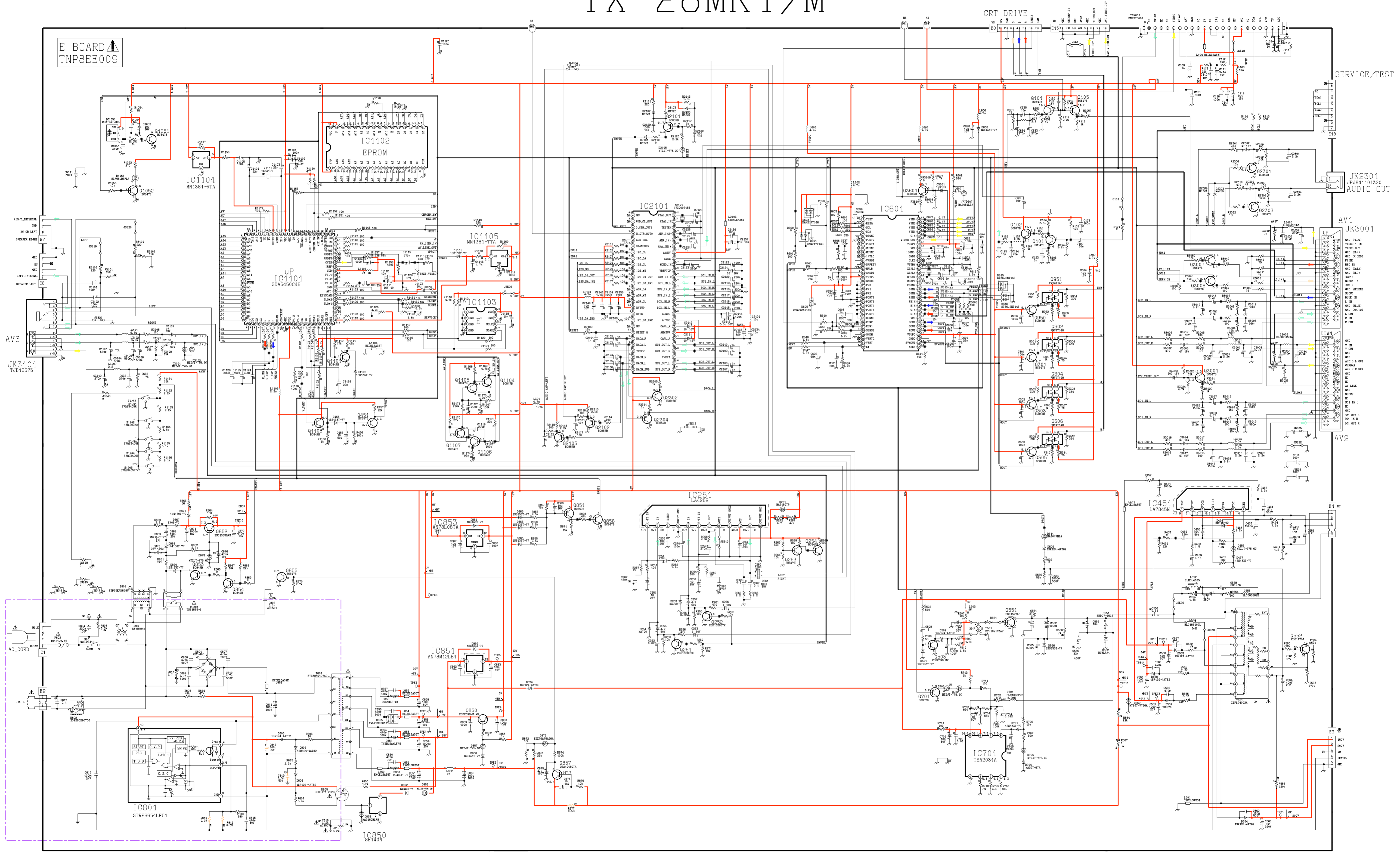



# TX-21MK1/M

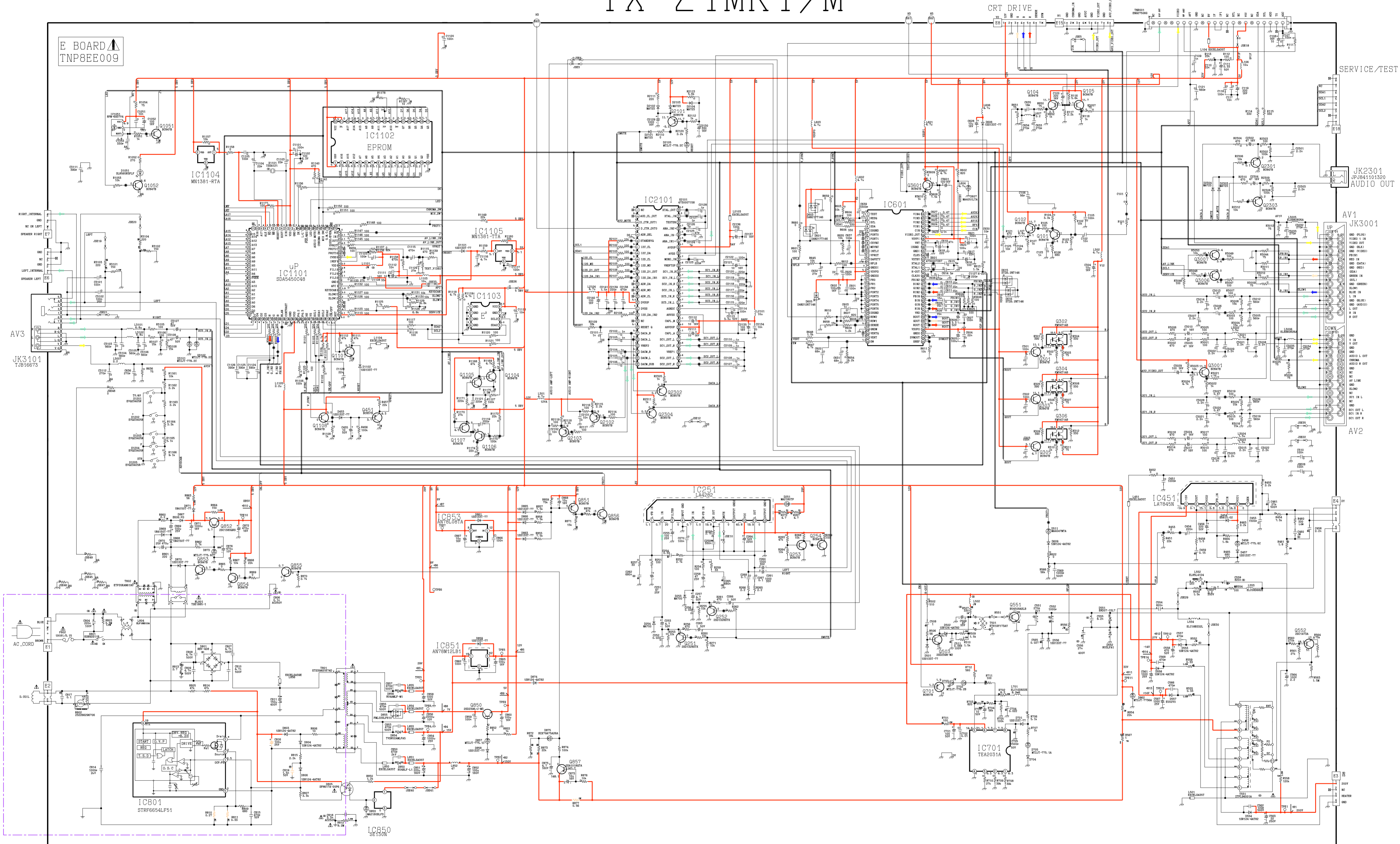



# TX-21MK1/M

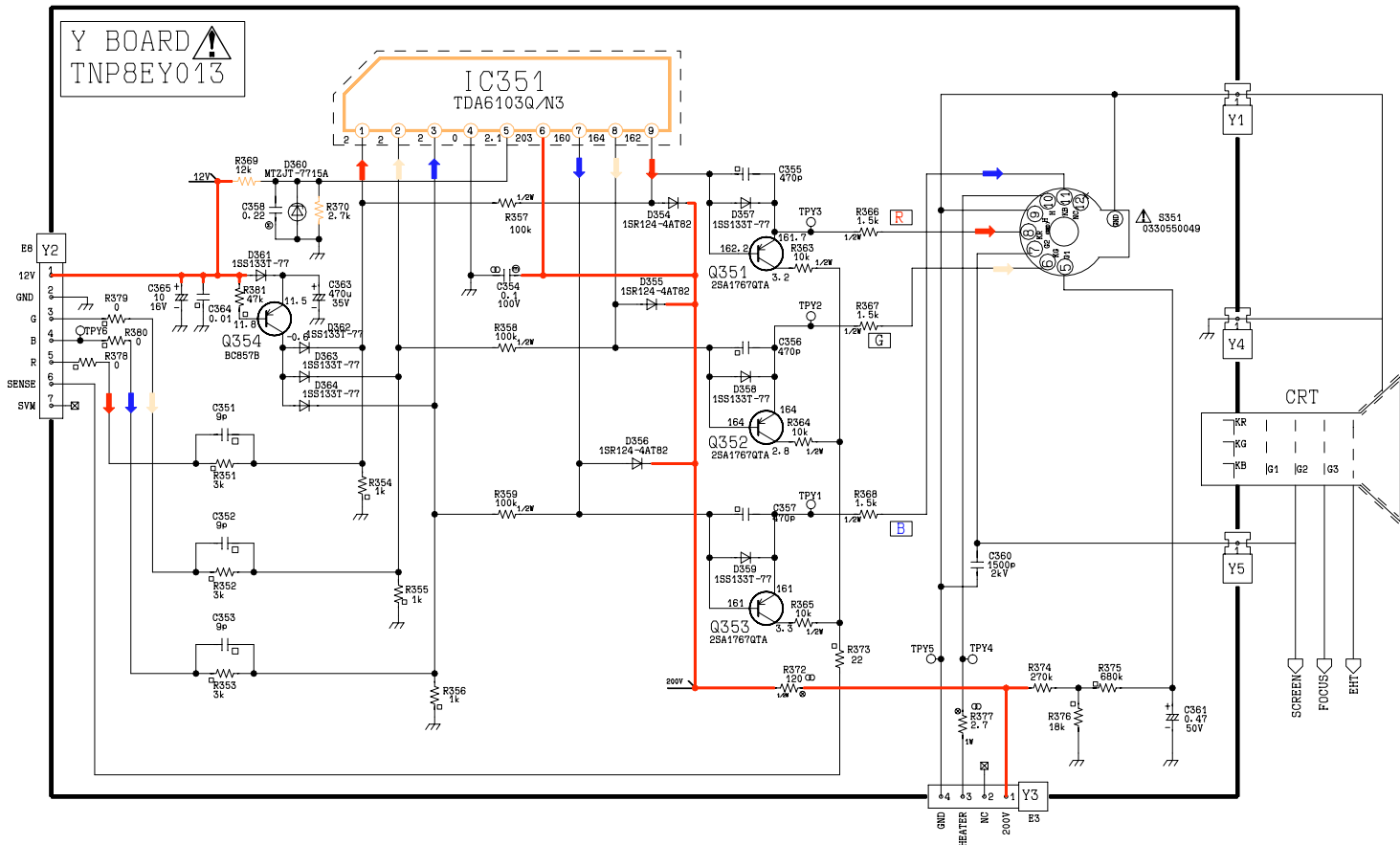



# CONDUCTOR VIEWS

## E-BOARD TNP8EE009

TRAN'S	DIODES	D558 L4
Q3601 L8	D3102 B7	D557 M3
Q3007 M9	D3101 B7	D556 K1
Q3006 N10	D2304 G7	D555 N3
Q3001 N8	D2303 G7	D554 N4
Q2304 I7	D2161 G9	D553 K4
Q2303 M6	D2105 G10	D552 J1
Q2302 I7	D2104 F9	D551 K3
Q2301 L6	D2103 G10	D511 M5
Q2103 I8	D2102 G9	D502 I2
Q2102 I8	D1103 F8	D501 I2
Q2101 G10	D1102 F7	D457 L5
Q1108 F9	D1101 G7	D456 L5
Q1107 C7	D1051 A9	D454 L5
Q1106 C7	D875 J5	D453 F9
Q1105 C7	D874 J4	D254 B5
Q1104 C7	D873 B5	D253 C4
Q1101 F7	D871 A5	D252 C4
Q1052 A9	D870 C4	D251 D4
Q1051 C8	D869 B4	
Q951 J9	D868 B4	<b>IC'S</b>
Q950 J9	D867 A3	IC2101 H8
Q857 J4	D866 I9	IC1105 F7
Q856 F9	D865 I9	IC1104 C9
Q855 J5	D864 I10	IC1103 F8
Q854 B4	D863 G9	IC1102 D10
Q853 B4	D862 N10	IC1101 D8
Q852 B5	D861 J9	IC1051 A10
Q850 F5	D860 I10	IC853 J9
Q701 J5	D859 H5	IC852 I10
Q552 N3	D858 E5	IC851 G5
Q551 K1	D857 E5	IC850 H4
Q503 I2	D856 F4	IC801 G2
Q451 F8	D855 F4	IC701 K5
Q305 K9	D854 G4	IC601 L7
Q304 K9	D853 H3	IC451 L5
Q303 K9	D852 I4	IC251 D6
Q302 J9	D851 I4	
Q301 K9	D850 H4	<b>TP'S</b>
Q253 C4	D806 G2	TPE14 M5
Q252 C4	D805 H2	TPE13 M4
Q251 D4	D804 H1	TPE12 K4
Q105 M8	D803 H1	TPE11 N5
Q104 M9	D802 G2	TPE10 B5
Q103 F10	D801 E1	TPE9 F5
Q102 G10	D705 J5	TPE8 F5
Q101 H10	D704 K5	TPE7 I9
	D703 K5	TPE6 J10
	D702 K5	TPE5 G5
	D701 K5	TPE4 G5
	D609 N5	TPE3 E5
	D607 L9	TPE2 I5
		TPE1 M4

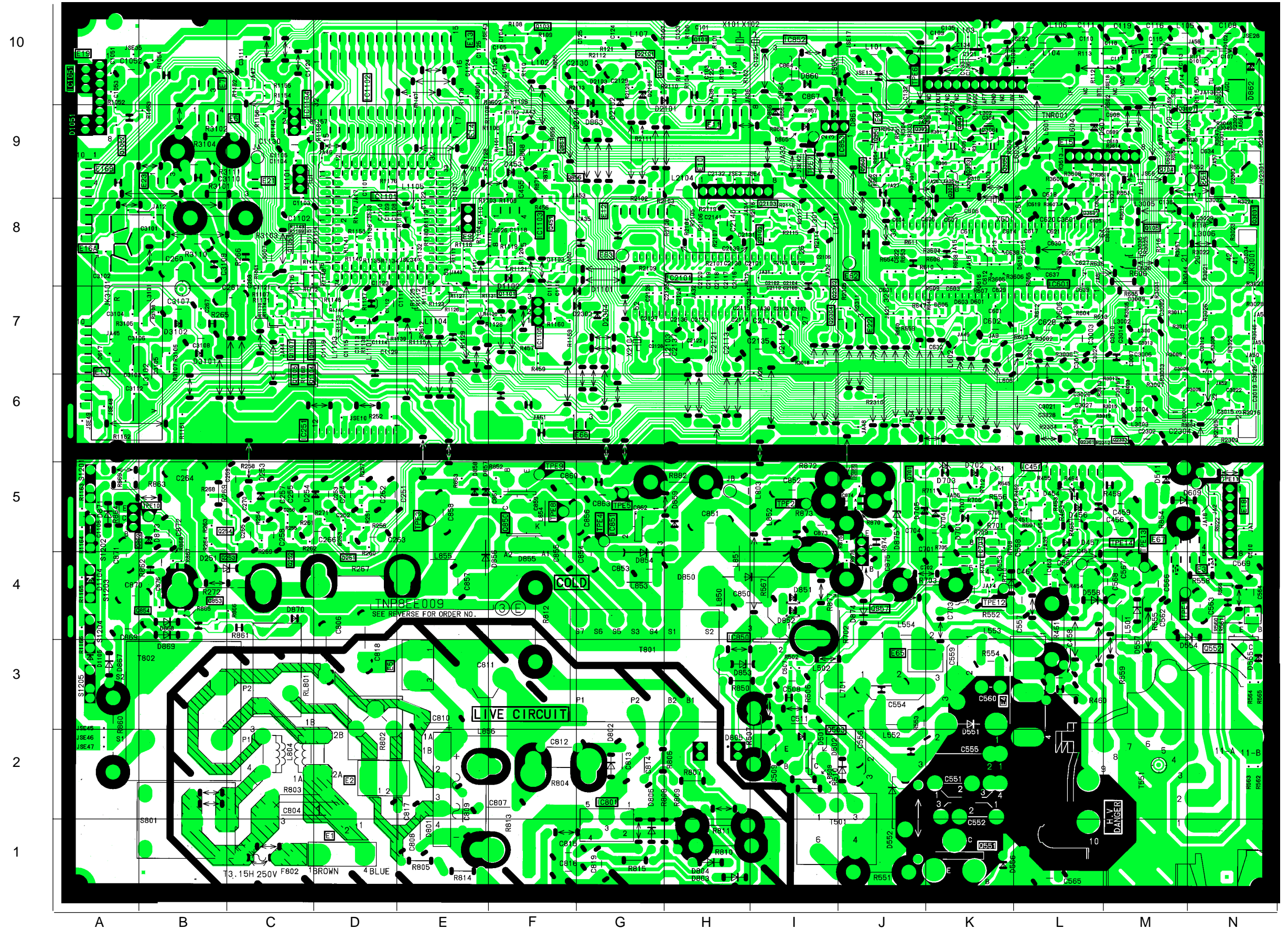

## Y - BOARD TNP8EY012

TRANSISTORS	
Q909	E1
Q908	C2
Q907	F4
Q906	G3
Q905	F5
Q354	A7
Q353	G6
Q352	F6
Q351	F6
DIODES	
D906	F1
D905	G4
D904	D3
D902	G4
D901	G3
D364	C9
D363	C8
D362	B9
D361	B7
D360	D8
D359	G6
D358	E7
D357	F7
D356	G7
D355	F7
D354	G7
TEST POINTS	
TPY6	B8
TPY5	D5
TPY4	E5
TPY3	F6
TPY2	E7
TPY1	G6
IC'S	
IC351	E8

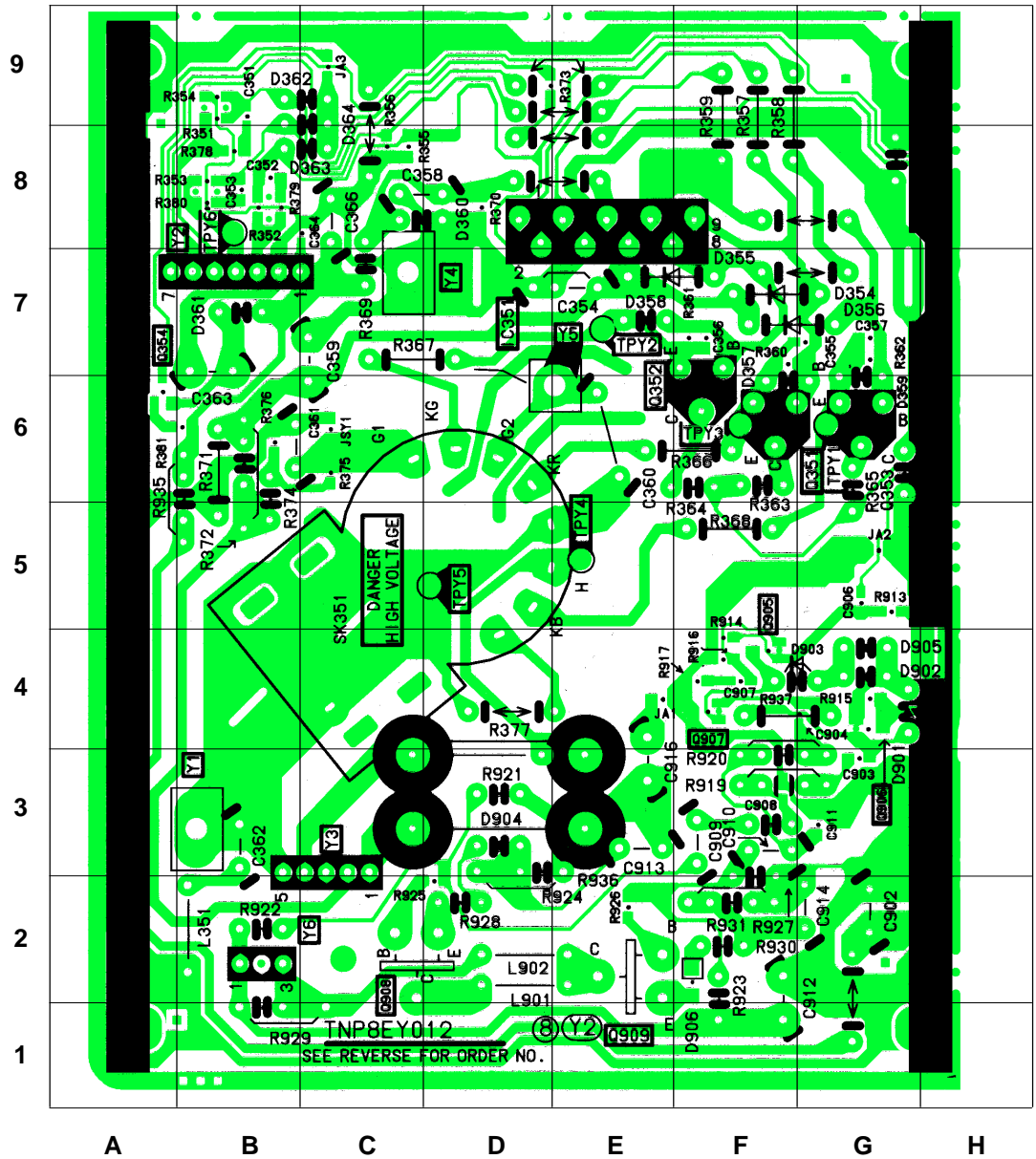

## Y - BOARD TNP8EY013

DIODES	
D354	G5
D355	F6
D356	G5
D357	G5
D358	F5
D359	G5
D360	C6
D361	B6
D362	D7
D363	D7
D364	D7
TEST POINTS	
TPY1	E4
TPY2	F5
TPY3	F4
TPY4	E3
TPY5	D3
TPY6	B6
TRANSISTORS	
Q351	G4
Q352	F4
Q353	G4
Q354	C7
I.C.'S	
IC351	E6

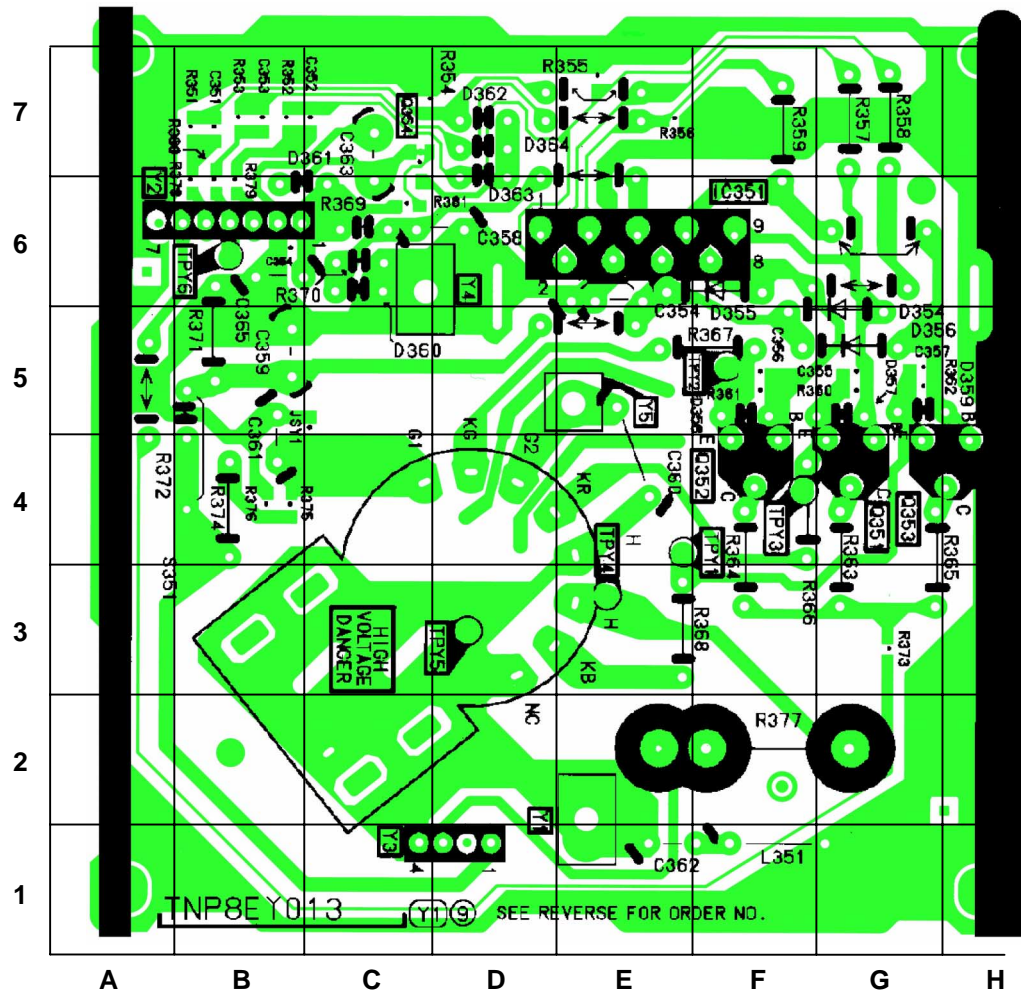

## H - BOARD TNP8EH002

TRANSISTORS	
Q3401	C3
Q3402	A2
I.C.'S	
IC3401	C2

